



SEPLoS SMART BMS3.0

16S150A Lithium battery management system specification

Model: SEPLoS 16S150A

www.seplos.com



CONTENT

1. Scope of application	1
2. Normative reference scope	1
3. Assembly	2
3.1 Dimensional drawing	2
3.2 Electrical characteristics	3
3.3 Installation method	3
3.3.1 BMS Interface definition	3
3.3.2 Sample harness definition	4
3.3.3 BMS and battery assembly method	6
3.4 communication	6
3.4.1 Matching inverter communication	6
3.4.2 Internal communication	7
3.5 Parallel communication	8
4. LED light indication	9
5. Parameter specification	10
6. Function description	17
6.1 ON/OFF	17
6.2 Voltage detection and protection	17
6.3 Current detection and protection	18
6.4 Temperature detection and protection	19
6.5 Balancing function	20
6.6 Temperature rise	20
6.7 Consumption	21
6.8 Storage	21
6.9 Pre-charge	21
6.11 One-button switch	22
6.12 Inverter matching protocol definition	22
6.14 External switch (optional)	23
6.15 Dry contact (optional)	24
6.16 LCD screen (optional)	24
6.17 Aerosol detection function	24
7. Precautions for use	26

1. Scope of application

This product fully supports the acquisition of eight-sixteen cells in series; eight cells in series only need to change the hardware power threshold and remove the high row plug; The fifteen series and sixteen series are fully compatible. It is only necessary to change the cell sampling line fifteen series and sixteen series together, and configure the number of series and total voltage protection parameters through the upper computer. BMS can match multiple inverter manufacturers through the upper computer setting protocol, with pre-charging function. BMS has multi-layer protection functions, including a series of protection and recovery functions such as Individual over voltage/under voltage, total voltage under voltage/over voltage, charge-discharge over current, charge-discharge secondary over current, charge-discharge high temperature, charge-discharge low temperature and short circuit. The SOC, SOH and total discharge capacity can be accurately calculated according to the characteristics of the cell. Parallel communication through RS485 and data monitoring through upper computer software. It can communicate with the inverter through CAN/485 .

2. Normative reference scope

The following documents are indispensable for the application of this document. For dated reference files, only the dated version applies to this file. For undated reference documents, the latest version (including all amendments) applies to this document.

GB/T 191	Pictorial marks for packaging, storage and transportation.
GB/T 2408-2008	Plastics Determination of combustion performance Horizontal and vertical methods
EN 61000-6	EMC (electromagnetic compatibility) test standard for electronic and electrical products
GB/T 17626.5-2008	Electromagnetic compatibility Test and measurement technology Surge (impact) immunity test
GB/T 17626.2-2006	Electromagnetic compatibility Test and measurement technology Electrostatic discharge immunity test
YD/T 2344.1—2011	Lithium iron phosphate battery pack for communication Part 1: Integrated battery pack

YD/T 2344.2—2015	Lithium iron phosphate battery pack for communication Part 2: Discrete battery pack
YD/T 1363.3	Centralized monitoring and management system for power supply, air conditioning and environment of communication bureau (station) Part 3: Front-end smart device protocol
GB/T 36558-2018	General technology of energy storage system

3. Assembly

3.1 Dimensional drawing

Length * width=350mm*100mm

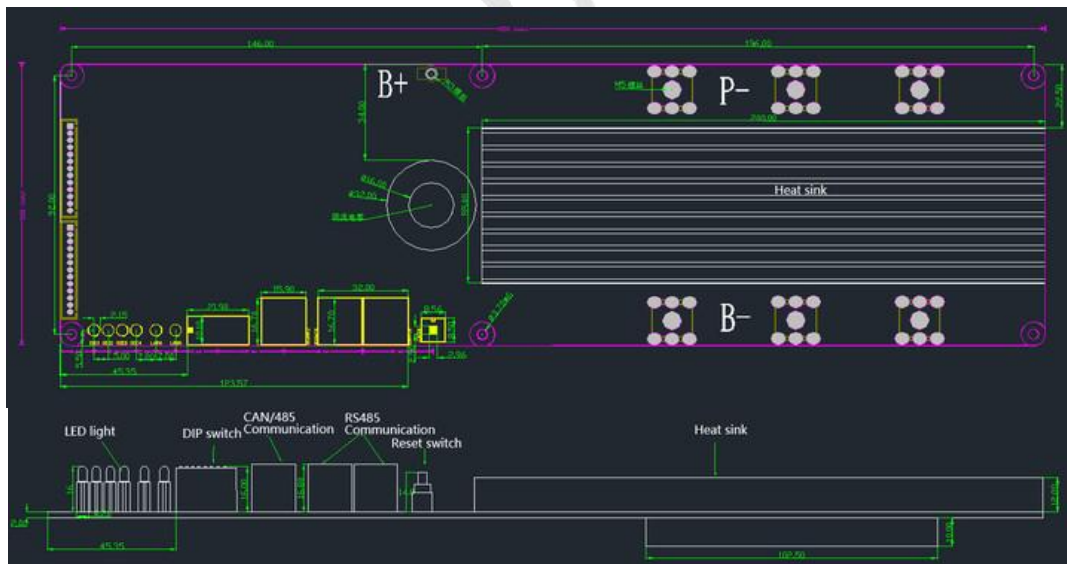

3.2 Electrical characteristics

Item	Min	Max	Type	Unit
working voltage	40	59	48	V
Charging voltage	48	60	54	V
working temperature	-20	70	25	C
Storage temperature	-40	85	25	C
Ambient humidity	10	85	-	%
Charge and discharge current	-	160	150	A
Internal resistance	<2			mΩ

3.3 Installation method

3.3.1 BMS Interface definition

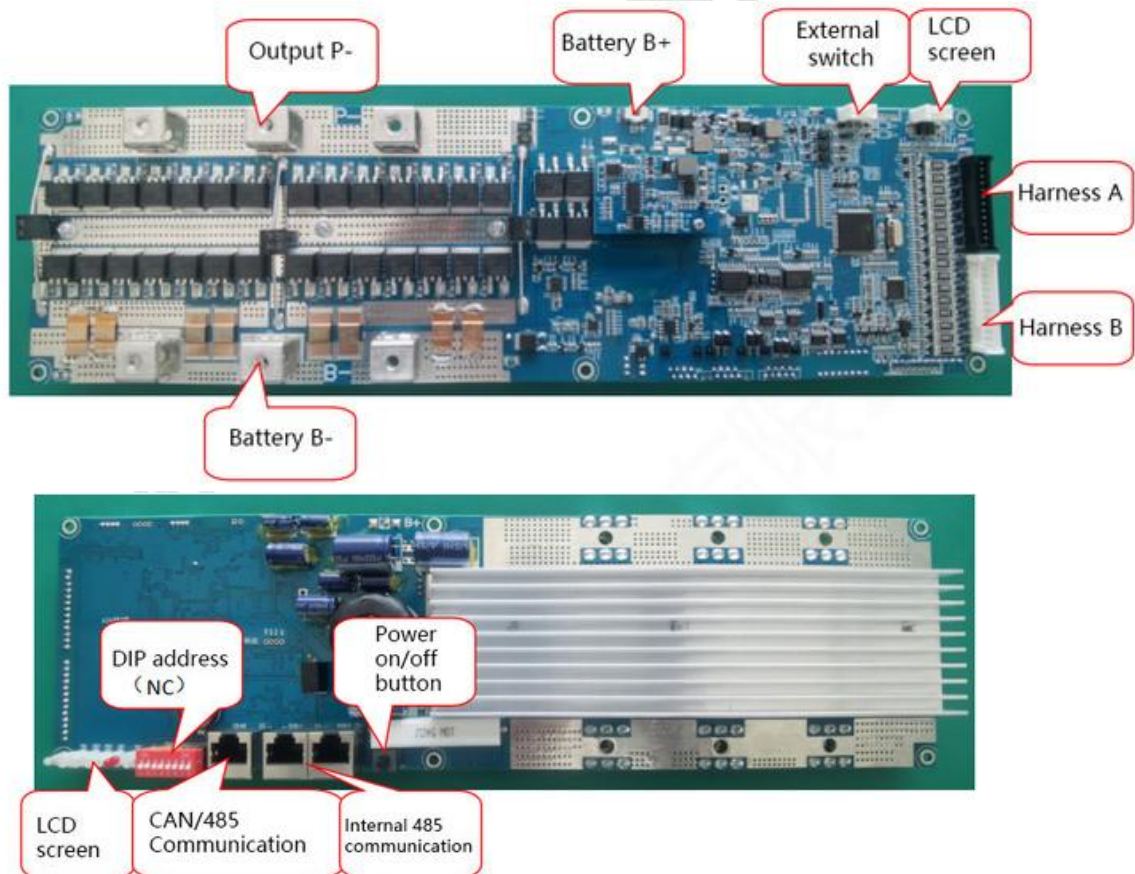

3.3.2 Sample harness definition

Harness A (black row plug)	
BMS Wiring definition	Cell wiring definition
CELL1-	Connected to the negative pole of the first battery
CELL1+	Connected to the positive pole of the first battery
CELL2+	Connected to the positive pole of the second battery
CELL3+	Connected to the positive pole of the third battery
CELL4+	Connected to the positive pole of the fourth battery
NTC1+	Connected to temperature sensorNTC1
NTC1-	Connected to temperature sensorNTC1
CELL5+	Connected to the positive pole of the fifth battery
CELL6+	Connected to the positive pole of the sixth battery
CELL7+	Connected to the positive pole of the seventh battery
CELL8+	Connected to the positive pole of the eighth battery
NTC2+	Connected to temperature sensorNTC2
NTC2-	Connected to temperature sensorNTC2

Harness B(white row plug)	
BMS Wiring definition	Cell wiring definition
CELL9-	Connected to the negative pole of the ninth battery
CELL9+	Connected to the positive pole of the ninth battery
CELL10+	Connected to the positive pole of the tenth battery
CELL11+	Connected to the positive pole of the eleventh battery
CELL12+	Connected to the positive pole of the twelfth battery
NTC3+	Connected to temperature sensorNTC3
NTC3-	Connected to temperature sensorNTC3
CELL13+	Connected to the positive pole of the thirteenth battery
CELL14+	Connected to the positive pole of the fourteenth battery
CELL15+	Connected to the positive pole of the fifteenth battery
CELL16+	Connected to the positive pole of the sixteenth battery
NTC4+	Connected to temperature sensorNTC4
NTC4-	Connected to temperature sensorNTC4

Actual wiring mode of sampling line and cell (As shown below)

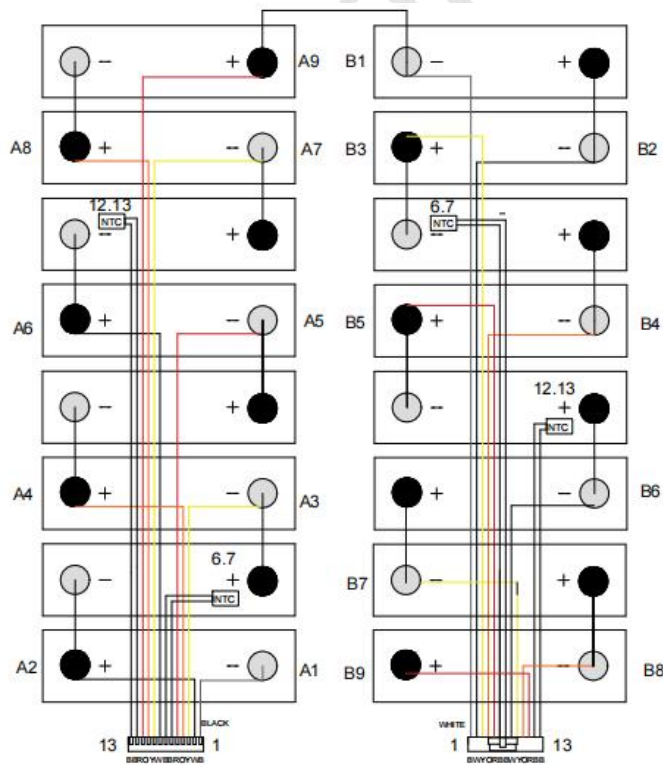

3.3.3 BMS and battery assembly method

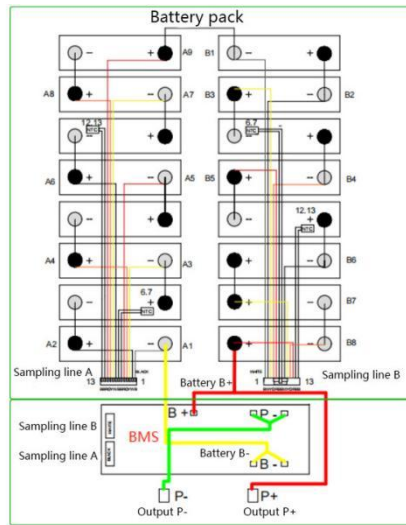

Assembly method of BMS and cell module : First battery B- — — Harness A — — Harness B — — Battery B+ (Battery B+ Line use M3 screw , Recommended use 16AWG harness , Battery B+The main reason is that the power supply can not meet the large current) — — output P- Negative pole of load or charger — — output P+Load or charger positive pole (Remark: The sampling line is not allowed to be connected incorrectly. The black row plug is connected to the white row plug or misalignment will burn out the sampling resistor.)

3.4 communication

3.4.1 Matching inverter communication

Define the corresponding BMS communication interface according to the communication interface of each inverter ; The definition of the special inverter communication port is inconsistent with that of the BMS communication port. You need to make your own network cable. If you use the conventional network cable, the BMS may automatically start or shut down; Generally, use the conventional network cable to communicate.

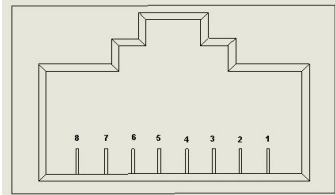
CAN/RS485	
	
Pin	Definition description
1、8	RS485-B
2、7	RS485-A
4	CAN-H
5	CAN-L
3、6	GND

3.4.2 Internal communication

Select the corresponding port and baud rate for BMS internal communication 19200

RS485A

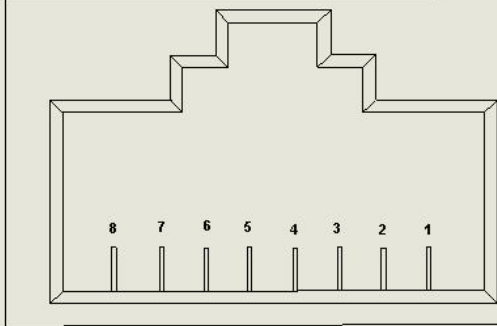

RS485B

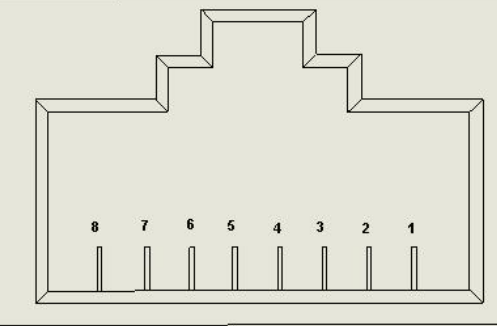

RS485A		RS485B	
Pin	Definition description	Pin	Definition description
1、 8	RS485-B	1、 8	RS485-B
2、 7	RS485-A	2、 7	RS485-A
3	Master flag enable	3	GND
4	Autocode address 2	4	Autocode address 1
5	GND	5	GND
6	GND	6	Salve flag enable

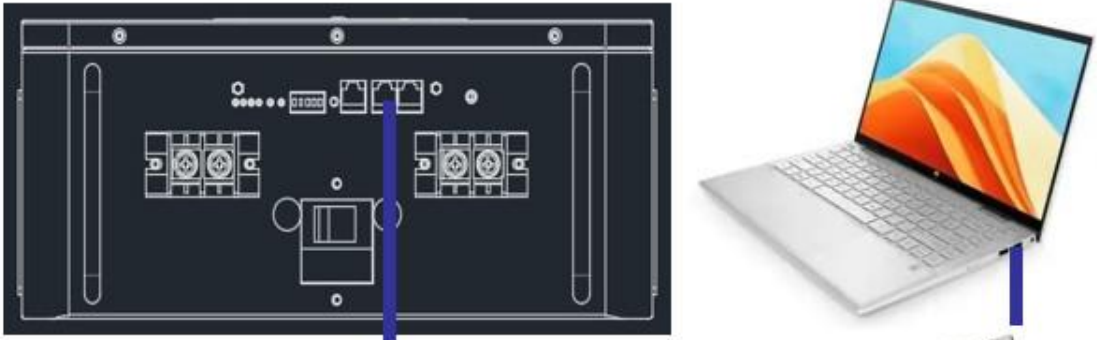

Pin1 (RS485-B)
Pin2 (RS485-A)

T/R+ (RS485-B)
T/R- (RS485-A)

Recommended model of USB to 485 adapter cable: Converter UT-890/891A

3.5 Parallel communication

BMS has the function of automatic address assignment without dialing (the dialing switch reserved on BMS is only a decoration to be compatible with the original battery case port design, and the dialing address can be optional without affecting the automatic address assignment of BMS), and the normal network cable can be used when the machine is connected.

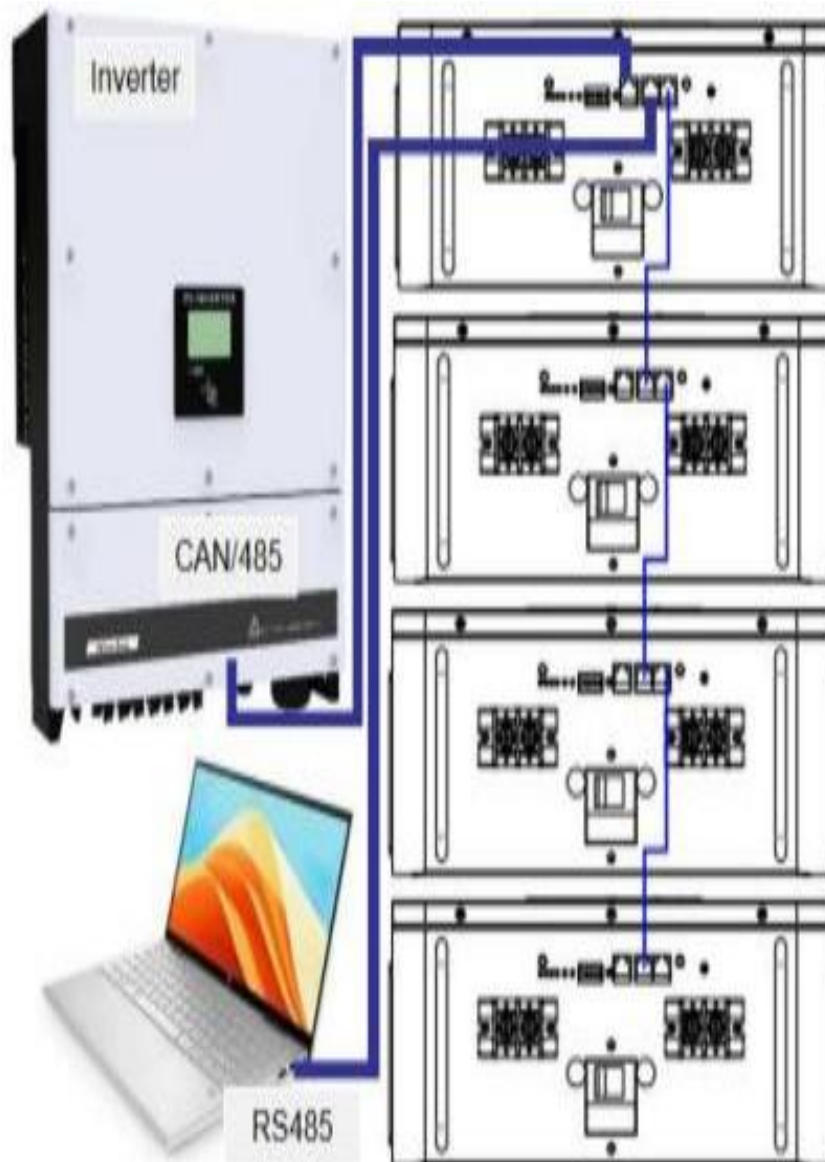

4. LED light indication

LED operation indication status

status	Normal/ alarm/ protection	RUN	ALN	Power indicator LED				Instruction
		●	●	●	●	●	●	
Shutdown	Dormancy	OFF	OFF	OFF				Total extinction
Stand- by	Normal	ON 1	OFF	OFF				Stand by statue
	Alarm	ON 1	ON 1	OFF				ALM and RUN lights flash synchronously 1
Charge	Normal	Green	OFF	According to power indication				Maximum LED flashing 2
	Over voltage alarm	Green	OFF	According to power indication				Maximum LED flashing 2
	Over current alarm	Green	ON 2	According to power indication				Maximum LED flashing 2
	Over voltage protection	ON 1	OFF	OFF				Switch to standby mode
Discharge	Normal	ON 3	OFF	According to power indication				According to the electric quantity
	Alarm	ON3	ON3	According to power indication				
	Under voltage protection	OFF	OFF	OFF				Stop discharging and shutdown
	Over current and short circuit protection	OFF	Red	OFF				
Temperature	Charging alarm	Green	ON2	According to power indication				
	Discharge alarm	ON 3	ON 3	According to power indication				
	Protect	OFF	Red	OFF				Close the corresponding MOS tube when the temperature reaches the protection value regardless of charging and discharging

LED Blink description

Blinking state	ON	OFF
Blink 1	0.25S	3.75S
Blink2	0.5S	0.5S
Blink3	0.5S	1.5S

Capacity indication

Statue		Charge				Discharge			
Capacity indicator		L4 ●	L3 ●	L2 ●	L1 ●	L4 ●	L3 ●	L2 ●	L1 ●
Quantity of electricity%	0~25%	OFF	OFF	OFF	Blink2	OFF	OFF	OFF	Green
	25~50%	OFF	OFF	Blink2	Green	OFF	OFF	Green	Green
	50~75%	OFF	Blink2	Green	Green	OFF	Green	Green	Green
	75~100%	Blink2	Green	Green	Green	Green	Green	Green	Green
Running indicator ●		Green				Blink3			

5. Parameter specification

Individual over /under voltage parameter					
Item		Default	Configurable Range	Set	Remarks (acceptable range 15S/ 16S)
Individual over voltage	Individual high voltage recovery	ON	Configurable	3.40V	3.37V~High voltage alarm
	Individual high voltage alarm		Configurable	3.50V	High voltage recovery~ Over voltage protection
	Individual Over voltage recovery	ON	Configurable	3.40V	High voltage recovery~ Over voltage protection
	Individual Over voltage protection		Configurable	3.65V	High voltage alarm~3.85V
	Over voltage recovery conditions	Individual voltage recovery or discharge current>3A			
Individual Under voltage	Individual Low voltage recovery	ON	Configurable	3.10V	Low voltage alarm~3.1V
	Individual Low voltage alarm		Configurable	2.90V	Low voltage recovery~ Low voltage recovery
	Individual Under voltage recovery	ON	Configurable	3.10V	Under voltage protection~ Low voltage recovery
	Individual Under voltage protection		Configurable	2.70V	2.5V~Low voltage recovery

	Under voltage recovery condition	Shutdown after under voltage protection requires charging activation or key activation
--	----------------------------------	--

Total voltage over /under voltage parameter					
Total voltage over voltage	Total voltage high voltage recovery	ON	Configurable	54.0V	51V~High voltage alarm
	Total voltage high voltage alarm		Configurable	56.0V	High voltage recovery~ Over voltage protection
	Total voltage over voltage recovery	ON	Configurable	54.0V	High voltage recovery~ Over voltage protection
	Total voltage over voltage protection		Configurable	57.6V	High voltage alarm~58V
	Total voltage recovery condition	Individual voltage recovery or discharge current>3A			
Total voltage under voltage	Total voltage low voltage recovery	ON	Configurable	48.0V	Low voltage alarm~49V
	Total voltage low voltage alarm		Configurable	46.4V	Low voltage recovery~ Low voltage recovery
	Total voltage under voltage recovery	ON	Configurable	48.0V	Under voltage protection~ Low voltage recovery
	Total voltage under voltage protection		Configurable	43.2V	40V~Low voltage alarm
	Under voltage recovery condition	Shutdown after under voltage protection requires charging activation or key activation			

Discharge/ Charging over current parameter					
Charging over current	Charging over current recovery	ON	Configurable	153A	Continuous charging current setting according to model selection
	Charging over current alarm		Configurable	155A	
	Charging over current protection	ON	Configurable	160A	
	Charging over current delay		Configurable	10S	1S~10S
	Charging secondary over current protection	ON	Configurable	250A	60s automatic recovery after over current protection
	Charging secondary over current delay		Configurable	300ms	

Discharge over current	Discharge over current recovery	ON	Configurable	153A	Continuous charging current setting according to model selection
	Discharge over current alarm		Configurable	155A	
	Discharge over current protection	ON	Configurable	160A	
	Discharge over current delay		Configurable	10S	1S~10S
	Discharge secondary over current protection	ON	Configurable	250A	60s automatic recovery after over current protection
	Discharge secondary over current delay		Configurable	300ms	

Discharging/ Charging temperature parameter					
Charging temperature	Charging High temperature recovery	ON	Configurable	4 7 °C	4 0 °C ~ High temperature alarm
	Charging high temperature alarm		Configurable	5 0 °C	High temperature recovery~ Over temperature protection
	Charging over- temperature recovery	ON	Configurable	5 0 °C	High temperature recovery~ Over temperature protection
	Charging over- temperature protection		Configurable	5 5 °C	High temperature alarm~ 6 5 °C
	Charging low- temperature recovery	ON	Configurable	5 °C	Low temperature alarm~ 1 0 °C
	Charging low temperature alarm		Configurable	2 °C	Under temperature protection~ low temperature recovery
	Charging under temperature recovery	ON	Configurable	0 °C	Under temperature protection~ low temperature recovery

	Charging under temperature protection		Configurable	- 10 °C	- 15 °C ~ Low temperature alarm
Discharge temperature	Discharge high temperature recovery	ON	Configurable	5 0 °C	4 5 °C ~ High temperature alarm
	Discharge high temperature alarm		Configurable	5 5 °C	High temperature recovery ~ over temperature protection
	Discharge over- temperature recovery	ON	Configurable	5 5 °C	High temperature recovery ~ over temperature protection
	Discharge over- temperature protection		Configurable	6 0 °C	High temperature alarm ~ 6 5 °C
	Discharge low- temperature recovery	ON	Configurable	3 °C	Low temperature alarm ~ 1 0 °C
	Discharge low temperature alarm		Configurable	- 10 °C	Under temperature protection ~ low temperature recovery
	Discharge under temperature recovery	ON	Configurable	0 °C	Under temperature protection ~ low temperature recovery
	Discharge under temperature protection		Configurable	- 15 °C	- 15 °C ~ Low temperature alarm

Ambient temperature parameter					
	Ambient high temperature recovery	ON	Configurable	4 7 °C	4 5 °C ~ High temperature alarm

Ambient temperature	Ambient high temperature alarm		Configurable	5 0 °C	High temperature recovery~ over temperature protection
	Ambient over- temperature recovery	ON	Configurable	5 5 °C	High temperature recovery~ over temperature protection
	Ambient Over temperature protection		Configurable	6 0 °C	High temperature alarm~ 6 5 °C
	Ambient Low- temperature recovery	ON	Configurable	3 °C	Low temperature alarm~ 1 0 °C
	Ambient Low temperature alarm		Configurable	0 °C	Under temperature protection~ low temperature recovery
	Ambient Under temperature recovery	ON	Configurable	0 °C	Under temperature protection~ low temperature recovery
	Ambient Under temperature protection		Configurable	- 10 °C	- 15 °C ~Low temperature alarm

Power temperature parameter					
Power temperature	Power high temperature alarm	ON	Configurable	9 5 °C	High temperature recovery~ over temperature protection
	Power high temperature recovery		Configurable	8 5 °C	4 5 °C ~ High temperature alarm
	Power over- temperature protection	ON	Configurable	1 1 0 °C	High temperature alarm~ 1 1 0 C

	Power over-temperature recovery		Configurable	8.5 °C	High temperature recovery~ over temperature protection
--	---------------------------------	--	--------------	--------	--

SOC parameter					
SOC	SOC Low recovery	ON	Configurable	15%	low alarm of SOC is only for prompt, without any action
	SOC Low alarm		Configurable	10%	
	SOC Protection recovery	OFF	Configurable	7%	SOC low protection stops discharging, and is off by default
	SOC Low protection		Configurable	5%	

Cell failure parameter					
Cell failure	Individual differential voltage alarm	ON	Configurable	500mV	Differential voltage alarm is only a prompt, without any action.
	Differential voltage alarm recovery		Configurable	300mV	
	Individual differential voltage protection	OFF	Configurable	1V	The differential voltage protection is invalid. After the failure, the LED will flash completely and shut down
	Differential voltage protection recovery		Configurable	0.5V	

Balancing parameter					
Balancing	Balancing opening voltage	ON	Configurable	3.4V	Equalization is divided into standby equalization and charging equalization, which can only be equalized after the opening conditions are met
	Balancing opening differential voltage		Configurable	0.05V	
	Balancing end differential voltage		Configurable	0.03V	

	Balancing high temperature prohibition	ON	Configurable	50 °C	The temperature is too high or too low, and the BMS does not allow equalization
	Balancing low temperature prohibition		Configurable	0 °C	
	Static equalization timing	ON	Configurable	10H	The equilibrium continues to reach the set time

Active /passive current limiting parameter					
Active current limiting		OFF	/		Constant 10A current limit
Passive current limiting	Duration of charging current limit	ON	Configurable	300S	Duration after current limit
	Pulse current limiting current		Configurable	150A	Current reaches the limit of opening condition
	Pulse current limiting time		Configurable	1S	Judge whether the pulse current lasts and turn on the passive current limiting function

Pre-charge parameter					
Pre-charge	Completion rate of short circuit pre-charge	ON	/	10%	This function is not allowed to be set. Judge the pre-charge and short circuit conditions
	Normal pre-charge completion rate		/	80%	
	Abnormal pre-charge completion rate		/	20%	
	Pre-charge timeout	ON	Configurable	3S	Duration after opening pre-charge

Heat parameter					
Heat	Cell heating stop	OFF	Configurable	10 °C	Charger online condition, heating only after reaching the set temperature
	Cell heating on		Configurable	0 °C	

Recommended inverter voltage and current parameter					
Recommended inverter voltage and current	Charge request voltage	ON	Configurable	57.6V	BMS sends a request to the inverter for recommended voltage and current
	Charge request current		Configurable	130A	
	Discharge request current		Configurable	130A	
Shutdown	Standby sleep timing	ON	Configurable	48H	Shutdown in long standby state

6. Function description

6.1 ON/OFF

Function	Instruction
ON/OFF	Press the ON/OFF key for more than 1 s, the LED lights turn on from the capacity indicator light in turn, and then release, and the BMS enters the power-on state
OFF/Dormant	Press the ON/OFF key for more than 3s, the LED lights turn on from the running light in turn, and then release, and the BMS enters the shutdown state

6.2 Voltage detection and protection

Function	Instruction
Voltage detection	The detection accuracy of cell voltage is $\pm 10\text{mV}$ at $0\sim 45\text{ }^{\circ}\text{C}$ and $\pm 30\text{mV}$ at $-20\sim 70\text{ }^{\circ}\text{C}$.
Individual Over voltage protection	When any section of the cell reaches the Individual over voltage protection value, BMS closes the charging tube and stops charging; When the voltage reaches the recovery value or the discharge current reaches more than 3A, the over voltage protection is removed.

Total voltage over voltage protection	When the voltage reaches the total voltage over voltage protection value, BMS closes the charging tube and stops charging; When the voltage reaches the recovery value or the discharge current reaches more than 3A, the over voltage protection is removed.
Individual Under voltage protection	When any section of the cell reaches the single under voltage protection value, BMS will turn off the discharge tube for less than 60s and enter the shutdown state; After the under voltage protection, the charging is activated or the button is pressed to start.
Total voltage under voltage protection	When the voltage reaches the single total voltage under voltage protection value, BMS turns off the discharge tube for 60s and enters the shutdown state; After the under voltage protection, the charging is activated or the button is pressed to start.

6.3 Current detection and protection

Function	instruction
Current detection	With charge and discharge current detection, the charge current is displayed as positive current, and the discharge current is displayed as negative current; The current sampling accuracy can reach $\pm 2\%$ at normal temperature.
Charging over current protection	When there is no charging current limiting function, the current reaches the charging over current protection value and reaches the delay time; BMS closes the charging tube and stops charging; When the BMS reaches the recovery delay, re-detect the external charger current or discharge (current above 3A) to remove the charging over current protection.
Charging secondary over current protection	When there is no charging current limiting function, the current reaches the charging secondary over current protection value and reaches the delay time; BMS closes the charging tube and stops charging; When the BMS reaches the recovery delay, re-detect the current of the external charger or discharge (current above 3A) to remove the charging secondary over current protection.
Discharge over current protection	The current reaches the discharge over current protection value and reaches the delay time; BMS closes the discharge tube and stops discharging; When the BMS reaches the recovery delay, re-detect the external load current or charge (current above 3A) to remove the discharge over current protection.

Discharge secondary over current protection	The current reaches the discharge secondary over current protection value and reaches the delay time; BMS closes the discharge tube and stops discharging; When the BMS reaches the recovery delay, re-detect the external load current or charge (current above 3A) to remove the discharge secondary over current protection.
---	---

6.4 Temperature detection and protection

Function	Instruction
Temperature detection	Have the temperature detection function of 4 cells, 1 environment and 1 MOS tube, and the temperature sampling accuracy can reach ± 2 at normal temperature; The core temperature sensor adopts 10K/3435/ NTC thermistor.
Charging over- temperature protection	Regardless of charging and discharging, when the temperature reaches the charging over-temperature protection value, close the charging tube and stop charging; If the temperature is less than the over-temperature recovery value, the BMS will resume charging.
Charging under temperature protection	Regardless of charging and discharging, when the temperature reaches the charging under temperature protection value, close the charging tube and stop charging; The BMS will resume charging when the temperature is greater than the temperature recovery value
Discharge over- temperature protection	Regardless of charging and discharging, when the temperature reaches the discharge over-temperature protection value, close the discharge tube and stop discharging; When the temperature is less than the over-temperature recovery value, BMS will resume discharging. (The charging temperature is also protected after the general discharge temperature protection, and the charging temperature setting value is lower than the discharge temperature setting value)
Discharge under temperature protection	Regardless of charging and discharging, when the temperature reaches the discharge under temperature protection value, close the discharge tube and stop discharging; The BMS will resume discharging when the temperature is greater than the temperature recovery value. (The charging temperature is also protected after the general discharge temperature protection, and the charging temperature setting value is higher than the discharge temperature setting value)

Ambient over/ under temperature protection	The NTC chip on the PCB board specially detects the internal temperature of the case, reaches the Over temperature/under-temperature protection value, and stops charging and discharging; Only when the ambient temperature reaches the recovery value can it be charged and discharged.
Power over- temperature protection	The NTC special power MOS tube temperature on the PCB board reaches the over-temperature protection value and stops charging and discharging; Only when the power temperature reaches the recovery value can it be charged and discharged.

6.5 Balancing function

Function	Instruction
Standby balance	BMS adopts energy consumption equalization circuit; When the equalizing opening voltage reaches the set value and the opening differential voltage, the equalizing is started; The default starting voltage is 3.4V, the equalizing current is $\geq 50\text{mA}$, and the equalizing resistance temperature is not more than $50\text{ }^{\circ}\text{C}$.
Charge balance	BMS adopts energy consumption equalization circuit; Under the charging state, when the equalizing opening voltage reaches the set value and the opening differential voltage, the equalizing is started; The default starting voltage is 3.4V, the equalizing current is $\geq 50\text{mA}$, and the equalizing resistance temperature is not more than $50\text{ }^{\circ}\text{C}$.
High/low temperature prohibited balance	The BMS stops equalizing when the temperature reaches the equalizing high/low temperature setting.
Balance timeout	The BMS stops balancing from the start of balancing to the setting time.

6.6 Temperature rise

Function	Instruction
Main heating components	The maximum temperature rise of BMS shall not exceed $70\text{ }^{\circ}\text{C}$ when the battery pack is discharged horizontally at the rated discharge current under the temperature of $25\text{ }^{\circ}\text{C}$; In the environment with a temperature of $55\text{ }^{\circ}\text{C}$, the battery pack is tested flat and discharged at 0.1C. BMS MOSFET is not protected.

6.7 Consumption

BMS working statue	BMS consumption
Standby time-limit flow module is not started	≤40mA
Start of standby time-limit flow module	≤60mA
Shut down/ hibernate	≤0uA
Power consumption of individual LCD screen	≤5mA

6.8 Storage

Function	Instruction
Historical data storage	State conversion, single battery voltage, total battery voltage, charging/discharging current, temperature, etc; Record in year/month/day/hour/minute/second, with storage capacity not less than 500 records; The principle of first in first out is adopted, and the stored content can be read through the monitoring interface.

6.9 Pre-charge

Function	Instruction
pre-charge in turning on	When BMS is turned off, press the key to start up, and the pre-charge function will be activated instantly to avoid short circuit protection caused by capacitive load.
Pre-charge in standby mode	BMS is suddenly connected to the capacitive load in standby mode. BMS detects that it is the capacitive load to pre-charge to avoid triggering the short-circuit protection.

6.10 Automatic dialing

Function	Instruction
Automatic address assignment	The automatic address assignment of the parallel machine must be connected to the internal communication line according to the parallel machine communication wiring method, otherwise the address cannot be automatically assigned. Please check the parallel machine communication method above.

6.11 One-button switch

Function	Instruction
One-button off	The host sends a command to the slave to shut down. The shutdown method is to shut down the host manually. The host will issue a command to the slave. The host will shut down after the slave is shut down step by step (manual shutdown of the slave is unable to achieve the one-button shutdown function).
One-button on	After any one is powered on, other groups of BMS will be activated gradually.

6.12 Inverter matching protocol definition

Inverter protocol	Corresponding upper computer switching protocol function
Pylon (CAN protocol)	Pylon_CAN
Growatt (CAN protocol)	Growatt_CAN
Goodwe (CAN protocol)	Goodwe_CAN
Sofar (CAN protocol)	Sofar_CAN
SMA (CAN protocol)	SMA_CAN
Victron (CAN protocol)	Victron_CAN
Studer (CAN protocol)	Studer_CAN
Ginlong (CAN protocol)	Ginlong_CAN
Voltronic (RS485 protocol)	Voltronic_485
SRNE (RS485 protocol)	SRNE_485
Growatt (RS485 protocol)	Growatt_485
Pylon (RS485 protocol)	Pylon_485
Deye (PylonRS485 protocol)	Deye_485

Remark: When paralleling, you only need to use the LCD screen (press the confirm button 2 times on the LCD screen, the switch is successful) or other external devices, and switch the protocol of the host.

6.13 Release control (optional)

Function	Instruction (Increasing this function requires supplementary hardware)
Control release disconnection output after BMS failure	The release is placed on the P-terminal, and the BMS can not close the charge and discharge in case of failure protection. The BMS will give the release voltage to disconnect the release, so that the BMS can not be charged and discharged externally

6.14 External switch (optional)

Function	Instruction (The hardware is satisfied, and the function is enabled and available)
BMS leads out a self-locking switch	The BMS itself comes with a reset switch, which is inconvenient for customers to turn on/off inside the chassis; BMS specially opened an external switch with 12V power supply, which is convenient for customers to switch on and off

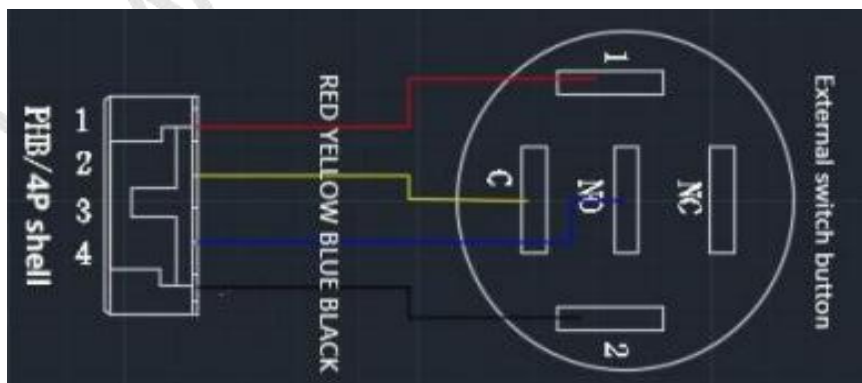

6.15 Dry contact (optional)

Function	Instruction (Increasing this function requires supplementary hardware)
2-way dry contact	BMS is equipped with 2-way dry contact function, and the principle design uses the wet-joint passive scheme; One channel is in alarm state and one channel is in protection state

6.16 LCD screen (optional)

Function	Instruction (Supporting LCD screen can be used directly)
LCD screen	BMS is equipped with LCD screen function. Now it is required to turn on the LCD display function through the parameter function switch of the upper computer, and connect the display screen to the BMS LCD screen interface for use; The LCD screen can switch the inverter protocol. Press the Enter key twice after the corresponding protocol, and the protocol will switch normally

6.17 Aerosol detection function(optional)

Function	Instruction (Adding this function requires changing the hardware, or direct LCD screen with aerosol)
Aerosol detection function	BMS has an aerosol function, the aerosol function and the LCD screen share the same socket, the function switch can only open one function, and the hardware is different, please confirm with the manufacturer if you need aerosol, the default hardware part does not have aerosol; open the aerosol Detection function, the default aerosol normally closed mode, the BMS detects whether the aerosol is closed; if the aerosol is disconnected, the BMS turns off the charge and discharge tube, and the 6 LED lights flash

Aerosol break mode	At the same time, the aerosol detection function and the aerosol normal-off mode are turned on, and the BMS detects whether the aerosol is disconnected; if the aerosol is closed, the BMS turns off the charge and discharge tube, and the 6 LED lights flash.
With aerosol on the LCD screen	There is an aerosol interface on the LCD screen, and the customer does not need to change the hardware of the main board with the LCD screen; the aerosol interface can be directly connected to the LCD screen, 2 choose 1, or the main board hardware is changed, or the LCD screen is used.

6.18 Bluetooth (optional)

Function	Instruction (Increasing this function requires supplementary hardware)
Bluetooth APP	Check the BMS data through the APP, and you can check the data of each group of batteries when you are in a stand-alone machine; when you are in parallel, you can view the parallel data through the host computer through Bluetooth; the Bluetooth model corresponding to the SN code on the LCD screen.

7. Precautions for use

- The battery management system cannot be used in series.
- The withstand voltage of BMS power components is 100V.
- If the cell module is assembled in the form of long conductor and long copper bar, it must communicate with BMS manufacturer to make impedance compensation. Otherwise, the consistency of the cell will be affected.
- During assembly, the protective plate shall not directly contact the surface of the core to avoid damage to the core. The assembly shall be firm and reliable.
- Pay attention not to touch the components on the circuit board with the lead head, soldering iron and soldering tin during use, otherwise the circuit board may be damaged.
- Pay attention to anti-static, moisture-proof, waterproof, etc. during use.
- Please follow the design parameters and service conditions during use, and the value in this specification shall not be exceeded, otherwise the protection plate may be damaged.
- After the battery pack and the protection board are assembled, if there is no voltage output or no charging when the battery is powered on for the first time, please check whether the wiring is correct. If there are still exceptions, please contact us.
- The management system has no 0V battery charging function. Once the battery is 0V, the battery performance will be seriously degraded, and may even be damaged. In order not to damage the battery, users need to recharge regularly when they are not in use for a long time (more than 3 months). When in use, the battery should be charged within 12 hours after being discharged to prevent the battery from discharging to 0V due to self-consumption.
- The management system is not equipped with anti-charge protection function, and the charging input cannot be reversed during use, otherwise the management system and battery may be damaged.
- The Company reserves the right of final interpretation.