



# TEST REPORT

Applicant: Gobel Power Energy (Shenzhen) Co., Ltd.

Address: Room 2626, 26th Floor, Ideal Mansion, No. 6 Meikang Road, Meilin Street, Futian District, Shenzhen, China

Manufacturer: Gobel Power Energy (Shenzhen) Co., Ltd.

Address: Room 2626, 26th Floor, Ideal Mansion, No. 6 Meikang Road, Meilin Street, Futian District, Shenzhen, China

EUT: LiFePO4 Server Rack Battery

Trade Mark: 

Model Number: GP-SR1-RN150

Date of Receipt: Nov. 29, 2022

Test Date: Nov. 29, 2022 - Dec. 02, 2022

Date of Report: Dec. 02, 2022

Prepared By: Shenzhen DL Testing Technology Co., Ltd.

Address: 101-201, Building C, Shuanghuan, No.8, Baoqing Road, Baolong Industrial Zone, Baolong Street, Longgang District, Shenzhen, Guangdong, China

Applicable Standards: EN IEC 61000-6-4:2019  
EN IEC 61000-3-2:2019+A1:2021, EN 61000-3-3:2013+A1:2019+A2:2021  
EN IEC 61000-6-2:2019  
EN 61000-4-2:2009, EN IEC 61000-4-3:2020, EN 61000-4-4:2012,  
EN 61000-4-5:2014+A1:2017, EN IEC 61000-4-6:2022, EN IEC 61000-4-11:2020

Test Result: Pass

Report Number: DL-20221202007E

Prepared (Engineer): Randy Xie

Reviewer (Supervisor): Jack Bu

Approved (Manager): Jade Yang



*This test report is based on a single evaluation of one sample of above mentioned products. It is not permitted to be duplicated in extracts without written approval of Shenzhen DL Testing Technology Co., Ltd.*



**TABLE OF CONTENT**

Test Report Declaration	Page
<b>1. VERSION .....</b>	<b>3</b>
<b>2. TEST SUMMARY.....</b>	<b>3</b>
<b>3. GENERAL INFORMATION .....</b>	<b>4</b>
<b>4. TEST INSTRUMENT USED.....</b>	<b>5</b>
<b>5. CONDUCTED EMISSION AT THE MAINS TERMINALS TEST.....</b>	<b>7</b>
<b>6. RADIATION EMISSION TEST.....</b>	<b>9</b>
<b>7. HARMONIC CURRENT EMISSION TEST .....</b>	<b>13</b>
<b>8. VOLTAGE FLUCTUATIONS &amp; FLICKER TEST .....</b>	<b>14</b>
<b>9. IMMUNITY TEST OF GENERAL THE PERFORMANCE CRITERIA.....</b>	<b>15</b>
<b>10. ELECTROSTATIC DISCHARGE IMMUNITY TEST .....</b>	<b>16</b>
<b>11. RF FIELD STRENGTH SUSCEPTIBILITY TEST .....</b>	<b>18</b>
<b>12. ELECTRICAL FAST TRANSIENT/BURST IMMUNITY TEST .....</b>	<b>20</b>
<b>13. SURGE TEST .....</b>	<b>21</b>
<b>14. INJECTED CURRENTS SUSCEPTIBILITY TEST .....</b>	<b>22</b>
<b>15. VOLTAGE DIPS AND INTERRUPTIONS TEST .....</b>	<b>24</b>
<b>16. SETUP PHOTOGRAPHS.....</b>	<b>25</b>
<b>17. EUT PHOTOGRAPHS.....</b>	<b>26</b>

**1. VERSION**

Version No.	Date	Description
00	Dec. 02, 2022	Original

**2. TEST SUMMARY**

EMC Emission				
Standard	Test Item	Limit	Result	Remark
EN 61000-6-4	Low voltage AC mains port	-----	N/A	
	Telecommunications/network port	-----	N/A	
	Radiated Emission below 1GHz	-----	PASS	
EN 61000-3-2	Harmonic Current Emission	Class A or D	N/A <sup>NOTE (2)</sup>	
EN 61000-3-3	Voltage Fluctuations & Flicker	-----	N/A	
EMC Immunity				
Section EN 61000-6-2	Test Item	Performance Criteria	Result	Remark
EN 61000-4-2	Electrostatic Discharge	B	PASS	
EN 61000-4-3	RF electromagnetic field	A	PASS	
EN 61000-4-4	Fast transients	B	N/A	
EN 61000-4-5	Surges	B	N/A	
EN 61000-4-6	Injected Current	A	N/A	
EN 61000-4-11	Volt. Interruptions Volt. Dips	C / C / C <sup>NOTE (3)</sup>	N/A	

**NOTE:**

(1) "N/A" denotes test is not applicable in this Test Report

(2) The power consumption of EUT is less than 75W and no Limits apply.

(3) Voltage dip: 70% reduction – Performance Criteria C

Voltage Interruptions: 30% reduction – Performance Criteria C

(4) Test Facility: Shenzhen DL Testing Technology Co., Ltd.

Address: 101-201, Building C, Shuanghuan, No.8, Baoqing Road, Baolong Industrial Zone, Baolong Street, Longgang District, Shenzhen, Guangdong, China



### 3. GENERAL INFORMATION

#### 3.1 Description of Device (EUT)

EUT: LiFePO4 Server Rack Battery

Trade Mark: 

Model Number: GP-SR1-RN150

Test Model: GP-SR1-RN150

Model difference: N/A

Power Supply: DC 51.2V

#### 3.2 Tested System Details

None.

#### 3.3 Block Diagram of Test Set-up

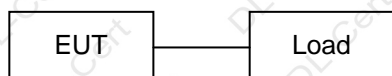

#### 3.4 Test Mode Description

Mode1. On Mode

#### 3.5 Test Auxiliary Equipment

None.

#### 3.6 Test Uncertainty

Conducted Emission Uncertainty :  $\pm 2.56\text{dB}$

Radiated Emission Uncertainty :  $\pm 3.24\text{dB}$

**4. TEST INSTRUMENT USED****For Conducted Emission Test(843 Shielded Room)**

Equipment	Manufacturer	Model	Serial	Last Cal.	Next Cal.
843 Shielded Room	ChengYu	843 Room	843	Sep. 20, 2022	Sep. 19, 2025
EMI Receiver	R&S	ESR	101421	Nov. 05, 2022	Nov. 04, 2023
LISN	R&S	ENV216	102417	Nov. 05, 2022	Nov. 04, 2023
Clamp	COM-POWER	CLA-050	431071	Nov. 05, 2022	Nov. 04, 2023
3-Loop Antenna	DAZE	ZN30401	13021	Nov. 05, 2022	Nov. 04, 2023
ISN T8	Schwarzbeck	NTFM 8158	101135	Nov. 05, 2022	Nov. 04, 2023
ISN T5	Schwarzbeck	NTFM 8158	101136	Nov. 05, 2022	Nov. 04, 2023
843 Cable 1#	ChengYu	CE Cable	001	Nov. 05, 2022	Nov. 04, 2023
843 Cable 1#	ChengYu	CE Cable	002	Nov. 05, 2022	Nov. 04, 2023

**For Radiated Emission Test(966 chamber)**

Equipment	Manufacturer	Model	Serial	Last Cal.	Next Cal.
966 chamber	ChengYu	966 Room	966	Sep. 20, 2022	Sep. 19, 2025
Spectrum Analyzer	Agilent	E4408B	MY50140780	Nov. 05, 2022	Nov. 04, 2023
EMI Receiver	R&S	ESRP7	101393	Nov. 05, 2022	Nov. 04, 2023
Amplifier	Schwarzbeck	BBV9743B	00153	Nov. 05, 2022	Nov. 04, 2023
Amplifier	EMEC	EM01G8GA	00270	Nov. 05, 2022	Nov. 04, 2023
Broadband Trilog Antenna	Schwarzbeck	VULB9162	00306	Nov. 05, 2022	Nov. 04, 2023
Horn Antenna	Schwarzbeck	BBHA9120D	02139	Nov. 05, 2022	Nov. 04, 2023
966 Cable 1#	ChengYu	966	004	Nov. 05, 2022	Nov. 04, 2023
966 Cable 2#	ChengYu	966	003	Nov. 05, 2022	Nov. 04, 2023

**For Harmonic & Flicker Test(EMS --- site )**

Equipment	Manufacturer	Model	Serial	Last Cal.	Next Cal.
Harmonics, Flicker & power Analyser	LAPLACE INSTRUMENTS	AC2000A	311370	Nov. 05, 2022	Nov. 04, 2023
AC Power Supply	MToni	HPF5010	633659	Nov. 05, 2022	Nov. 04, 2023

**For Electrostatic Discharge Immunity Test( EMS --- site )**

Equipment	Manufacturer	Model	Serial	Last Cal.	Next Cal.
ESD Tester	SCHLODER	SESD 230	17352	Nov. 05, 2022	Nov. 04, 2023

**For RF Field Strength Susceptibility Test(Keyway --- site)**

Equipment	Manufacturer	Model	Serial	Last Cal.	Next Cal.
Signal Generator	HP	8648A	3625U00573	Apr. 12, 2022	Apr. 11, 2023
Amplifier	A&R	500A100	17034	Apr. 12, 2022	Apr. 11, 2023
Amplifier	A&R	100W/1000M1	17028	Apr. 12, 2022	Apr. 11, 2023
Audio Analyzer (20Hz~1GHz)	Panasonic	2023B	202301/428	Apr. 12, 2022	Apr. 11, 2023
Isotropic Field Probe	A&R	FP2000	16755	Apr. 12, 2022	Apr. 11, 2023
Antenna	EMCO	3108	9507-2534	Apr. 12, 2022	Apr. 11, 2023
Log-periodic Antenna	A&R	AT1080	16812	Apr. 12, 2022	Apr. 11, 2023

**For EFT /B, Surge, Voltage Dips Interruptions Test(EMS --- site )**

Equipment	Manufacturer	Model	Serial	Last Cal.	Next Cal.
Transient Comprehensive Immunity Test System	Graphtec	HVIP16T+HCO MPACT 5	192501+192202	Nov. 05, 2022	Nov. 04, 2023
Coupling Clamp	HTEC	001	0001	Nov. 05, 2022	Nov. 04, 2023

**For Injected Currents Susceptibility Test(EMS --- site )**

Equipment	Manufacturer	Model	Serial	Last Cal.	Next Cal.
C/S Test System	LIONCEL	RIS-6091-85	0191101	Nov. 05, 2022	Nov. 04, 2023
CDN	LIONCEL	CDN-M2-16	0191001	Nov. 05, 2022	Nov. 04, 2023
CDN	LIONCEL	CDN-M3-16	0191002	Nov. 05, 2022	Nov. 04, 2023
Injection Clamp	Frankonia	EMCL-20	18101728-0108	Nov. 05, 2022	Nov. 04, 2023

Item	Name	Manufacturer	Model	Software version
1	EMC Conduction Test System	FALA	EZ_EMCC	EMC-CON 3A1.1
2	EMC radiation test system	FALA	EZ_EMCC	FA-03A2
3	RF test system	MAIWEI	MTS8310	2.0.0.0
4	RF communication test system	MAIWEI	MTS8200	2.0.0.0

**5. CONDUCTED EMISSION AT THE MAINS TERMINALS TEST**

5.1 Block Diagram of Test Setup

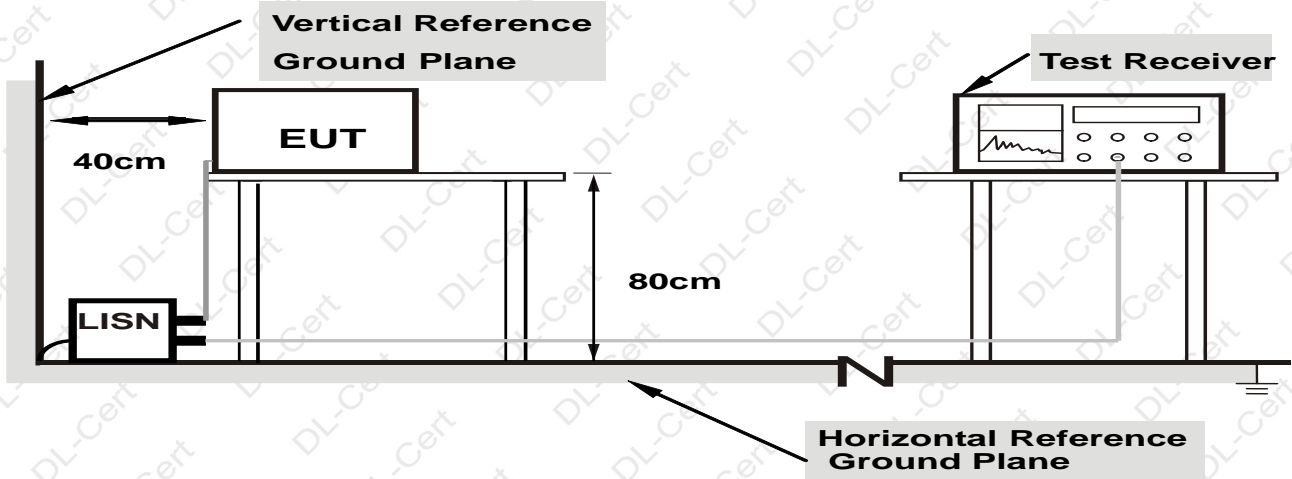

- Note:**
1. Support units were connected to second LISN.
  2. Both of LISNs (AMN) are 80 cm from EUT and at least 80 cm from other units and other metal planes

5.2 Test Standard and Limit  
EN 61000-6-4

Frequency MHz	Limits dB(μV)			
	At mains terminals		At Telecommunications/network port	
	Quasi-peak Level	Average Level	Quasi-peak Level	Average Level
0.15~0.50	79	73	97-87	84-74
0.50~30.00	66	60	87	74

- Notes:
1. \*Decreasing linearly with logarithm of frequency.
  2. The lower limit shall apply at the transition frequencies.

5.3 EUT Configuration on Test

The following equipment's are installed on conducted emission test to meet EN 61000-6-4 requirement and operating in a manner which tends to maximize its emission characteristics in a normal application.

5.4 Operating Condition of EUT

- 5.4.1 Setup the EUT and simulators as shown in Section 5.1.
- 5.4.2 Turn on the power of all equipment.
- 5.4.3 Let the EUT work in test modes and test it.



#### 5.5 Test Procedure

The EUT is put on the ground and connected to the AC mains through a Artificial Mains Network (AMN). This provided a 50ohm coupling impedance for the tested equipment. Both sides of AC line are checked to find out the maximum conducted emission levels according to the **EN 61000-6-4** regulations during conducted emission test.

The bandwidth of the test receiver (R&S Test Receiver ESR) is set at 10KHz.

The frequency range from 150 KHz to 30 MHz is investigated.

#### 5.6 Test Result

The EUT is powered by DC, no requirements for this item.

## 6. RADIATION EMISSION TEST

### 6.1 Block Diagram of Test Setup

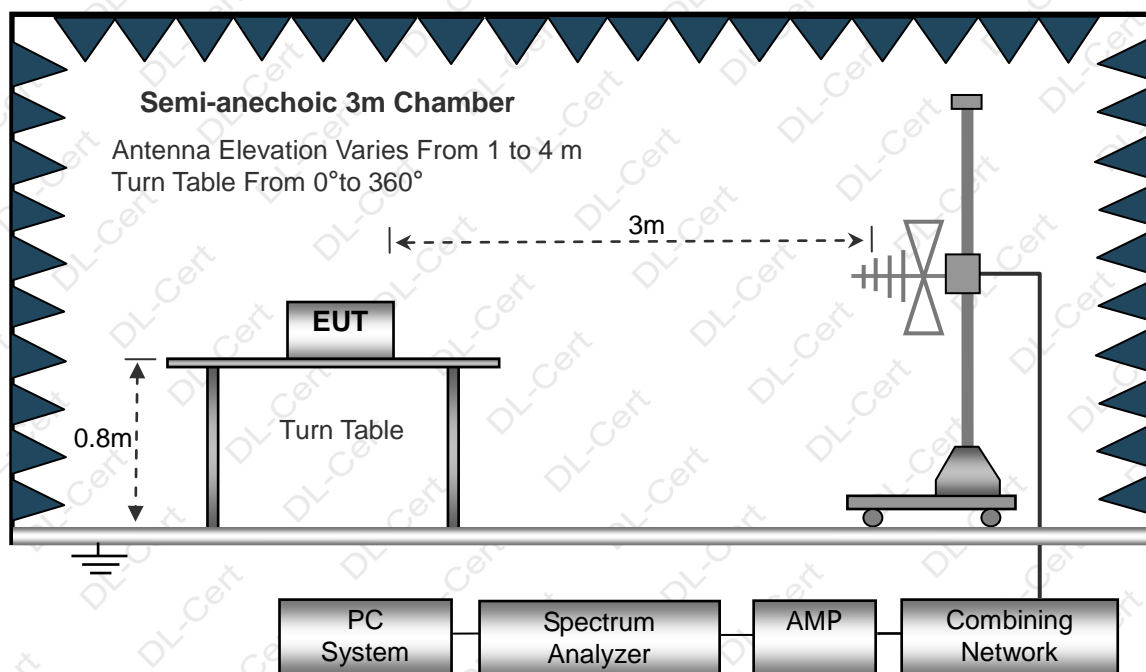

### 6.2 Test Standard and Limit

EN 61000-6-4

Frequency MHz	Distance (Meters)	Field Strengths Limits dB(μV)/m
30~230	3	50.0
230~1000	3	57.0

Remark:

- (1) The smaller limit shall apply at the cross point between two frequency bands.
- (2) Distance refers to the distance in meters between the measuring instrument, antenna and the closed point of any part of the device or system.

### 6.3 EUT Configuration on Test

The EN 61000-6-4 regulations test method must be used to find the maximum emission during radiated emission test.

The configuration of EUT is the same as used in conducted emission test.

Please refer to Section 2.2.

### 6.4 Operating Condition of EUT

Same as conducted emission test, which is listed in Section 2.2 except the test set up replaced as Section 4.1.



#### 6.5 Test Procedure

- 1) The radiated emissions test was conducted in a semi-anechoic chamber.
- 2) The tabletop EUT was placed upon a non-metallic table 0.8m above the ground reference plane. And for floor-standing arrangement, the EUT was placed on the horizontal ground reference plane, but separated from metallic contact with the ground reference plane by 0.1m of insulation.
- 3) Before final measurements of radiated emissions, a pre-scan was performed in the spectrum mode with the peak detector to find out the maximum emissions spectrum plots of the EUT.
- 4) The frequencies of maximum emission were determined in the final radiated emissions measurement. At each frequency, the EUT was rotated 360°, and the antenna was raised and lowered from 1 to 4 meters in order to determine the maximum disturbance. Measurements were performed for both horizontal and vertical antenna polarization.
- 5) The bandwidth setting on the field strength meter (R&S Test Receiver ESCI) is set at 120KHz.
- 6) The frequency range from 30MHz to 1000MHz is checked.

#### 6.6 Test Result

PASS

Please refer to the following page.



Radiation Emission Test Data			
Temperature:	24.5 °C	Relative Humidity:	54%
Pressure:	1009hPa	Polarization:	Horizontal
Test Voltage:	DC 51.2V	Test Mode:	Mode 1

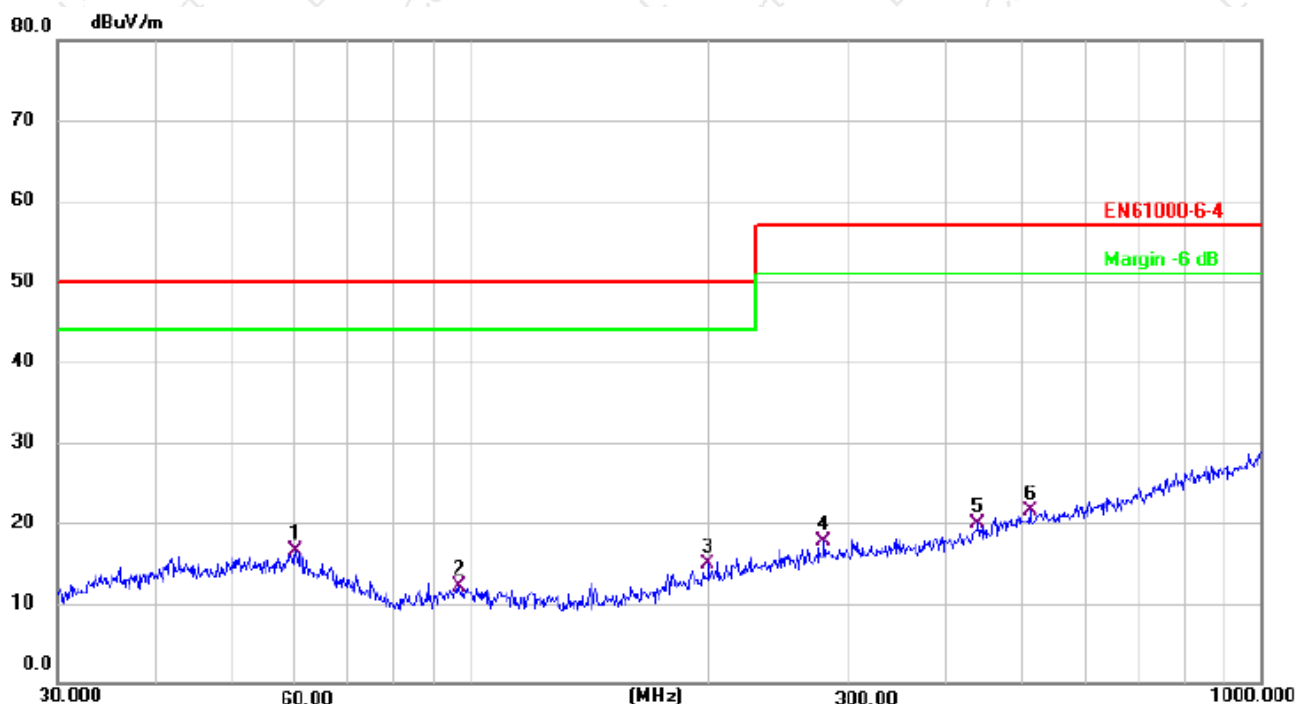

No.	Mk.	Freq. MHz	Reading Level dBuV	Correct Factor dB	Measure- ment dBuV/m	Limit dB/m	Margin dB	Detector
1	*	60.0691	27.65	-11.18	16.47	50.00	-33.53	QP
2		96.7749	27.28	-15.27	12.01	50.00	-37.99	QP
3		199.9855	28.18	-13.30	14.88	50.00	-35.12	QP
4		280.0237	28.74	-11.12	17.62	57.00	-39.38	QP
5		438.6554	28.17	-8.31	19.86	57.00	-37.14	QP
6		510.0435	28.22	-6.65	21.57	57.00	-35.43	QP

Remark:

Correct Factor=Cable loss+Antenna factor-Preamplifier

Measurement Level = Reading Level + Correct Factor; Margin = Measurement Level- Limit;



Radiation Emission Test Data			
Temperature:	24.5 °C	Relative Humidity:	54%
Pressure:	1009hPa	Polarization:	Vertical
Test Voltage:	DC 51.2V	Test Mode:	Mode 1

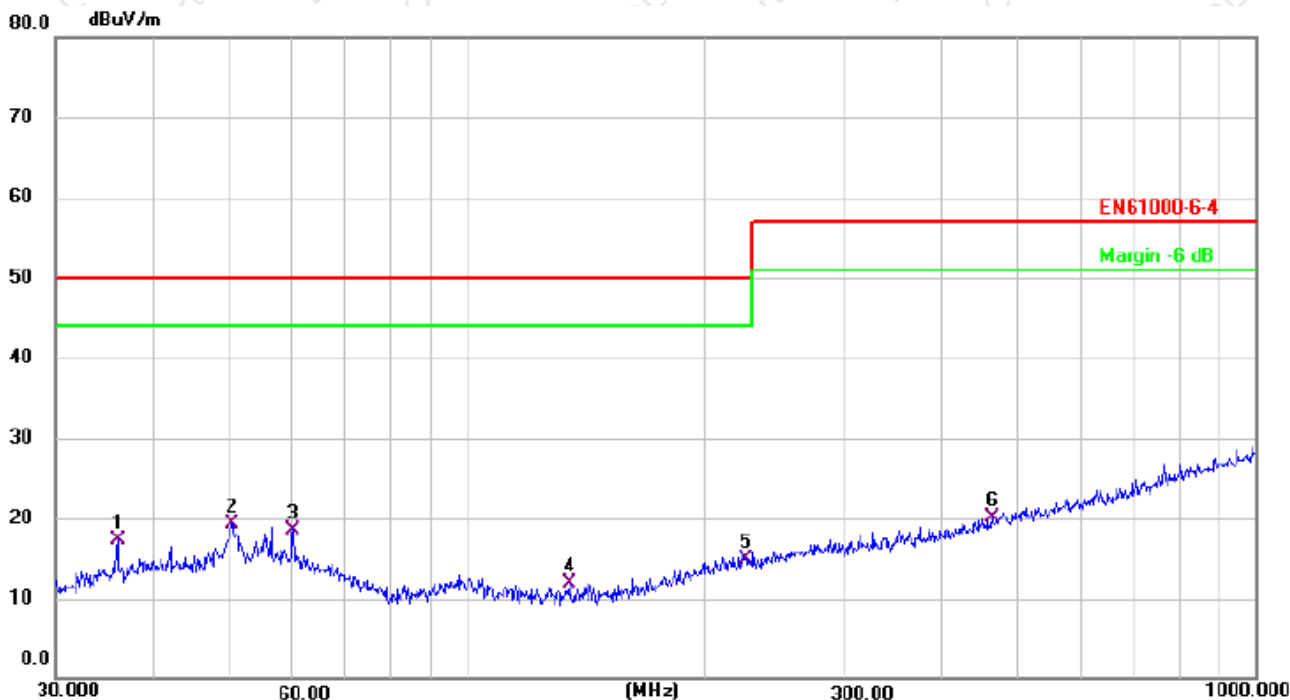

No.	Mk.	Freq. MHz	Reading Level dBuV	Correct Factor dB	Measure- ment dBuV/m	Limit dB/m	Margin dB	Detector
1		36.0007	30.71	-13.48	17.23	50.00	-32.77	QP
2	*	50.2324	30.44	-11.12	19.32	50.00	-30.68	QP
3		60.0691	30.58	-11.98	18.60	50.00	-31.40	QP
4		134.5592	27.99	-16.01	11.98	50.00	-38.02	QP
5		225.3080	26.95	-11.96	14.99	50.00	-35.01	QP
6		462.3455	26.79	-6.77	20.02	57.00	-36.98	QP

Remark:

Correct Factor=Cable loss+Antenna factor-Preamplifier

Measurement Level = Reading Level + Correct Factor; Margin = Measurement Level- Limit;



## 7. HARMONIC CURRENT EMISSION TEST

### 7.1 Block Diagram of Test Setup

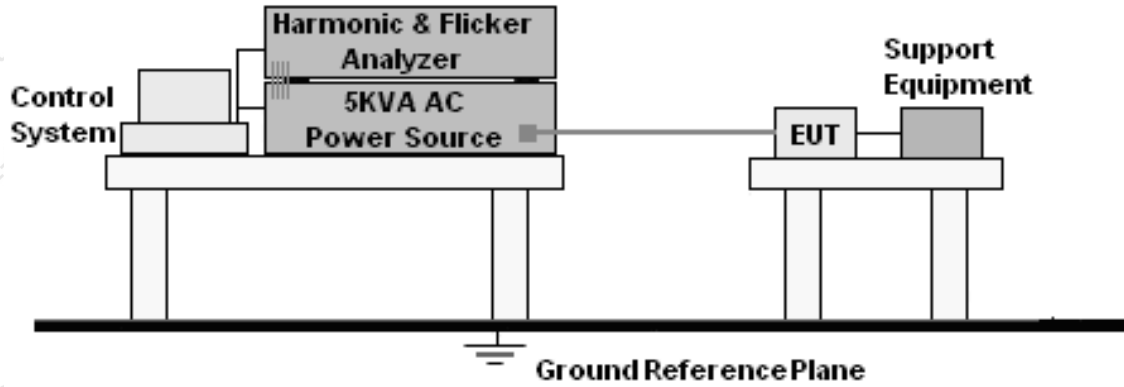

### 7.2 Test Standard

EN 61000-3-2

### 7.3 Operating Condition of EUT

Setup the EUT as shown in Section 8.1.

Turn on the power of all equipment.

Let the EUT work in test mode and test it.

### 7.4 Test Procedure

The power cord of the EUT is connected to the output of the test system. Turn on the power of the EUT and use the test system to test the harmonic current level.

### 7.5 Test Results

The EUT is powered by DC, no requirements for this item.



## 8. VOLTAGE FLUCTUATIONS & FLICKER TEST

### 8.1 Block Diagram of Test Setup

Same as Section 8.1.

### 8.2 Test Standard

EN 61000-3-3

### 8.3 Operating Condition of EUT

Same as Section 8.3. The power cord of the EUT is connected to the output of the test system. Turn on the power of the EUT and use the test system to test the harmonic current level.

#### Flicker Test Limit

Test items	Limits
Pst	1.0
dc	3.3%
Tmax	4.0%
dt	Not exceed 3.3% for 500ms

### 8.4 Test Procedure

The power cord of the EUT is connected to the output of the test system. Turn on the power of the EUT and use the test system to test the harmonic current level.

### 8.5 Test Results

The EUT is powered by DC, no requirements for this item.

**9. IMMUNITY TEST OF GENERAL THE PERFORMANCE CRITERIA**

<b>Product Standard</b>	<b>EN 61000-6-2</b>
<b>CRITERION A</b>	<p>The apparatus shall continue to operate as intended during and after the test. No degradation of performance or loss of function is allowed below a performance level specified by the manufacturer, when the apparatus is used as intended.</p> <p>The performance level may be replaced by a permissible loss of performance. If the minimum performance level or the permissible performance loss is not specified by the manufacturer, either of these may be derived from the product description and documentation and what the user may reasonably expect from the apparatus if used as intended.</p>
<b>CRITERION B</b>	<p>The apparatus shall continue to operate as intended after the test. No degradation of performance or loss of function is allowed below a performance level specified by the manufacturer, when the apparatus is used as intended.</p> <p>The performance level may be replaced by a permissible loss of performance. During the test, degradation of performance is however allowed. No change of actual operating state or stored data is allowed. If the minimum performance level or the permissible performance loss is not specified by the manufacturer, either of these may be derived from the product description and documentation and what the user may reasonably expect from the apparatus if used as intended.</p>
<b>CRITERION C</b>	<p>Temporary loss of function is allowed, provided the function is self-recoverable or can be restored by the operation of the controls.</p>

## 10. ELECTROSTATIC DISCHARGE IMMUNITY TEST

### 10.1 Block Diagram of Test Setup

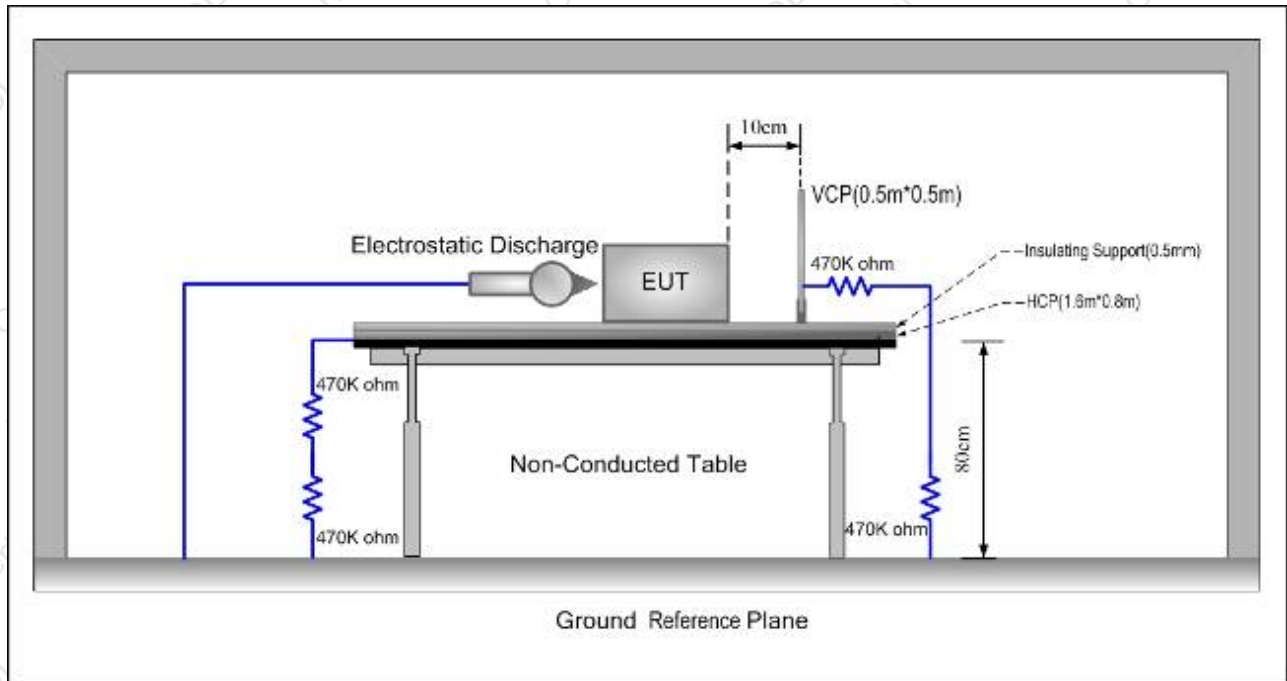

### 10.2 Test Standard

EN 61000-6-2, EN 61000-4-2

### 10.3 Severity Levels and Performance Criterion

Severity Level: 3 / Air Discharge:  $\pm 8\text{KV}$

Level: 2 / Contact Discharge:  $\pm 4\text{KV}$

Performance criterion: B

### 10.4 Test Procedure

- Electrostatic discharges were applied only to those points and surfaces of the Product that are accessible to users during normal operation.
- The test was performed with at least ten single discharges on the pre-selected points in the most sensitive polarity.
- The time interval between two successive single discharges was at least 1 second.
- The ESD generator was held perpendicularly to the surface to which the discharge was applied and the return cable was at least 0.2 meters from the Product.
- Contact discharges were applied to the non-insulating coating, with the pointed tip of the generator penetrating the coating and contacting the conducting substrate.
- Air discharges were applied with the round discharge tip of the discharge electrode approaching the Product as fast as possible (without causing mechanical damage) to touch the Product. After each discharge, the ESD generator was removed from the Product and re-triggered for a new single discharge. The test was repeated until all discharges were complete.
- At least ten single discharges (in the most sensitive polarity) were applied to the Horizontal Coupling Plane at points on each side of the Product. The ESD generator was positioned vertically at a distance of 0.1 meters from the Product with the discharge electrode touching the HCP.



h. At least ten single discharges (in the most sensitive polarity) were applied to the center of one vertical edge of the Vertical Coupling Plane in sufficiently different positions that the four faces of the Product were completely illuminated. The VCP (dimensions 0.5m x 0.5m) was placed vertically to and 0.1 meters from the Product.

10.5 Test Results

PASS

Please refer to the following page.

Electrostatic Discharge Test Data							
Temperature:		25.1°C		Humidity:		55%	
Power Supply:		DC 51.2V		Test Mode:		Mode 1	
Discharge Method	Discharge Position	Voltage (±kV)	Min. No. of Discharge per polarity (Each Point)	Required Level	Result		
Contact Discharge	Conductive Surfaces	4	10	B	Pass		
	Indirect Discharge HCP	4	10	B	Pass		
	Indirect Discharge VCP	4	10	B	Pass		
Air Discharge	Slots, Apertures, and Insulating Surfaces	8	10	B	Pass		

Note: N/A

## 11. RF FIELD STRENGTH SUSCEPTIBILITY TEST

### 11.1 Block Diagram of Test Setup

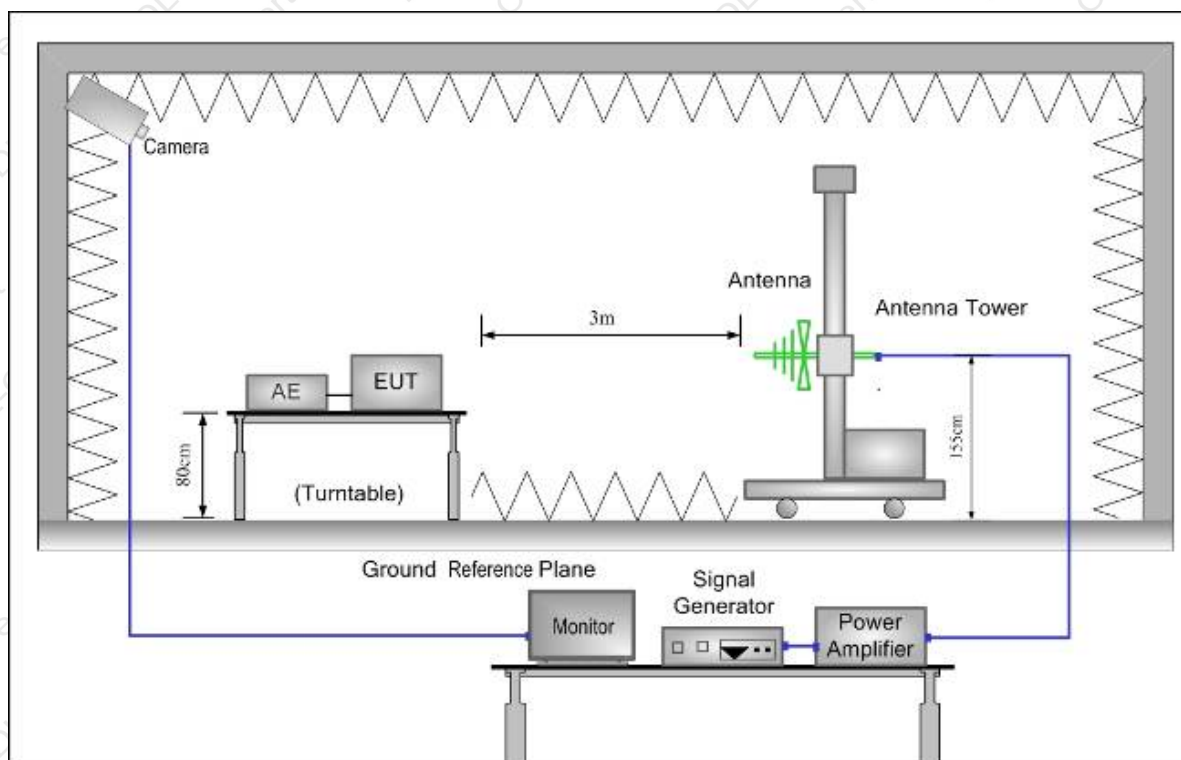

### 11.2 Test Standard

EN 61000-6-2, EN 61000-4-3

### 11.3 Severity Levels and Performance Criterion

Severity Level 2, 3V / m

Performance criterion: A

### 11.4 Test Procedure

The EUT and its simulators are placed on a turn table which is 0.8 meter above ground. EUT is set 3 meter away from the transmitting antenna which is mounted on an antenna tower. Both horizontal and vertical polarization of the antenna are set on test. Each of the four sides of EUT must be faced this transmitting antenna and measured individually.

All the scanning conditions are as follows:

Condition of Test	Remarks
Fielded Strength	10 V/m (Severity Level 2)
Radiated Signal	Modulated
Scanning Frequency	80 – 3000 MHz
Dwell time of radiated	0.0015 decade/s
Waiting Time	1 Sec.



11.5 Test Results

PASS

Please refer to the following page.

R/S Test Data				
Temperature:	25.1°C	Humidity:	55%	
Power Supply :	DC 51.2V	Test Mode:	Mode 1	
Criterion:	A	Steps	1 %	
Frequency (MHz)	Position	Field Strength (V/m)	Required Level	Result
80 – 1000	Front, Right, Back, Left	10	A	Pass
1400-2000	Front, Right, Back, Left	3	A	Pass
2000-2700	Front, Right, Back, Left	1	A	Pass
Note: N/A				

## 12. ELECTRICAL FAST TRANSIENT/BURST IMMUNITY TEST

### 12.1 Block Diagram of EUT Test Setup

For input a.c. / d.c. power port:

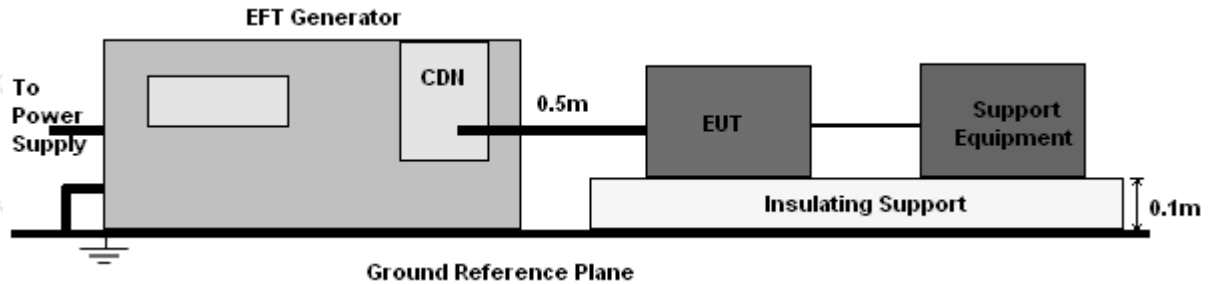

For signal lines and control lines:

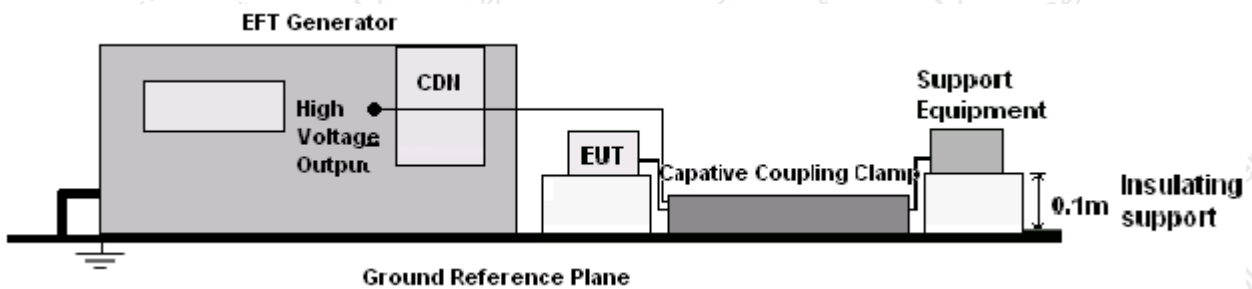

### 12.2 Test Standard

EN 61000-6-2, EN 61000-4-4

### 12.3 Severity Levels and Performance Criterion

Severity Level 2 at 2KV, Pulse Rise time & Duration: 5 nS / 50 nS

Performance criterion: B

### 12.4 Test Procedure

EUT shall be placed 0.8m high above the ground reference plane which is a min.1m\*1m metallic sheet with 0.65mm minimum thickness. This reference ground plane shall project beyond the EUT by at least 0.1m on all sides and the minimum distance between EUT and all other conductive structure, except the ground plane beneath the EUT, shall be more than 0.5m

For input and output AC power ports:

The EUT is connected to the power mains by using a coupling device which couples the EFT interference signal to AC power lines. Both polarities of the test voltage should be applied during compliance test and the duration of the test is 2 minutes.

### 12.5 Test Results

The EUT is powered by DC, no requirements for this item.

### 13. SURGE TEST

#### 13.1 Block Diagram of EUT Test Setup

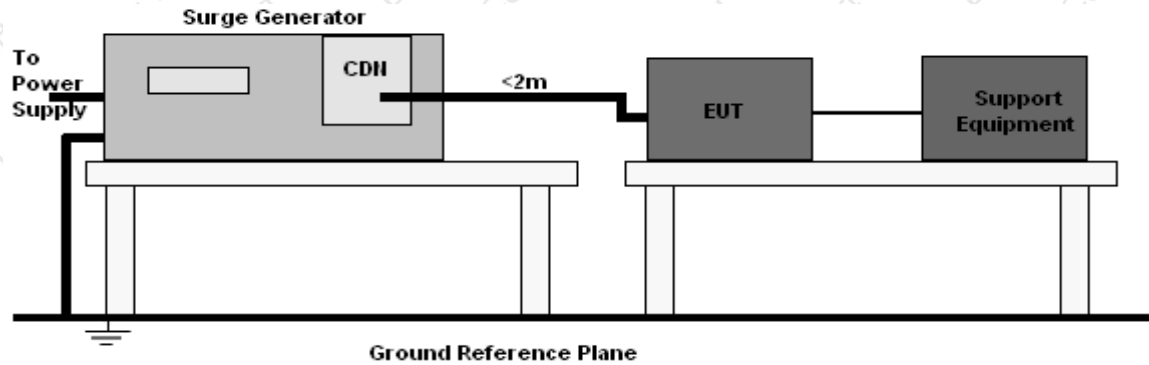

#### 13.2 Test Standard

EN 61000-6-2, EN 61000-4-5

#### 13.3 Severity Levels and Performance Criterion

Severity Level: Line to Line, Level 2 at 1KV;

Severity Level: Line to Earth, Level 3 at 2KV.

Performance criterion: B

#### 13.4 Test Procedure

- 1) Set up the EUT and test generator as shown on section 11.1
- 2) For line to line coupling mode, provide a 1KV 1.2/50us voltage surge (at open-circuit condition) and 8/20us current surge to EUT selected points.
- 3) At least 5 positive and 5 negative (polarity) tests with a maximum 1/min repetition rate are conducted during test.
- 4) Different phase angles are done individually.
- 5) Repeat procedure 2) to 4) except the open-circuit test voltage change from 1KV to 2KV for line to earth coupling mode test.
- 6) Record the EUT operating situation during compliance test and decide the EUT immunity criterion for above each test.

#### 13.5 Test Result

The EUT is powered by DC, no requirements for this item.

## 14. INJECTED CURRENTS SUSCEPTIBILITY TEST

### 14.1 Block Diagram of EUT Test Setup

For input a.c. / d.c. power port:

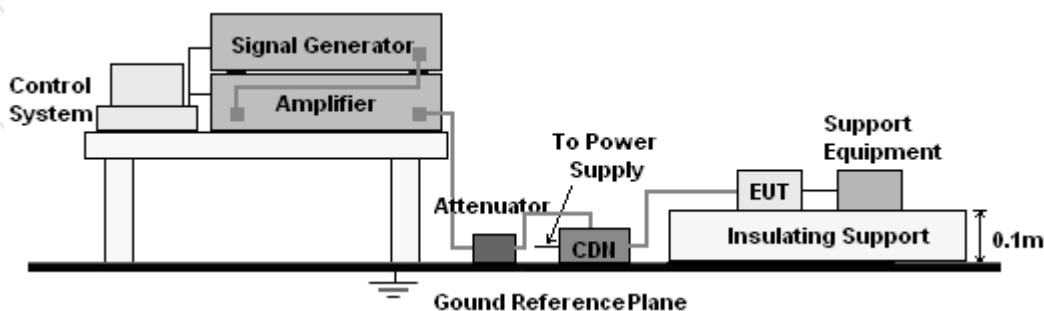

For signal lines and control lines:

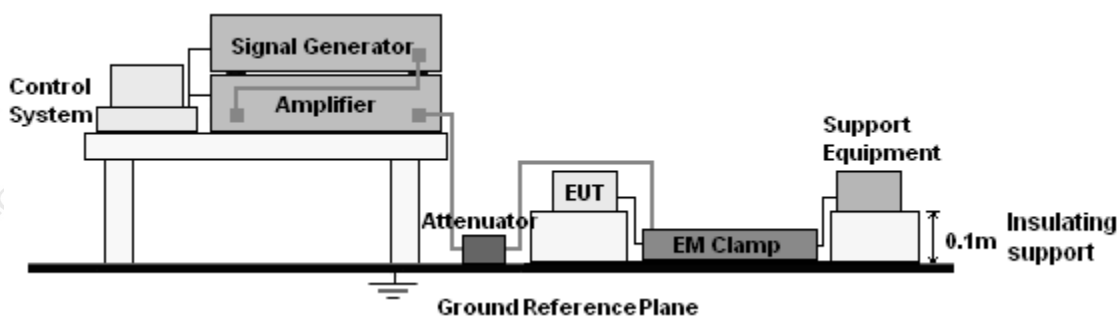

### 14.2 Test Standard

EN 61000-6-2, EN 61000-4-6

### 14.3 Severity Levels and Performance Criterion

Severity Level 2: 10V( rms ), 150KHz □ 80MHz

Performance criterion: A

### 14.4 Test Procedure

- 1) Set up the EUT, CDN and test generator as shown on section 12.1
- 2) Let EUT work in test mode and measure.
- 3) The EUT and supporting equipments are placed on an insulating support 0.1m high above a ground reference plane. CDN (coupling and decoupling device) is placed on the ground plane at above 0.1-0.3m from EUT. Cables between CDN and EUT are as short as possible, and their height above the ground reference plane shall be between 30 and 50 mm (where possible).
- 4) The disturbance signal described below is injected to EUT through CDN.
- 5) The EUT operates within its operational mode(s) under intended climatic conditions after power on.
- 6) The frequency range is swept from 150KHz to 80MHz using 3V signal level, and with the disturbance signal 80% amplitude modulated with a 1KHz sine wave
- 7) The rate of sweep shall not exceed  $1.5 \times 10^{-3}$  decades/s. Where the frequency is swept



incrementally, the step size shall not exceed 1% of the start and thereafter 1% of the preceding frequency value.

8) Recording the EUT operating situation during compliance test and decide the EUT immunity criterion for above each test.

#### 14.5 Test Result

The EUT is powered by DC, no requirements for this item.



**15. VOLTAGE DIPS AND INTERRUPTIONS TEST**

**15.1 Block Diagram of EUT Test Setup**

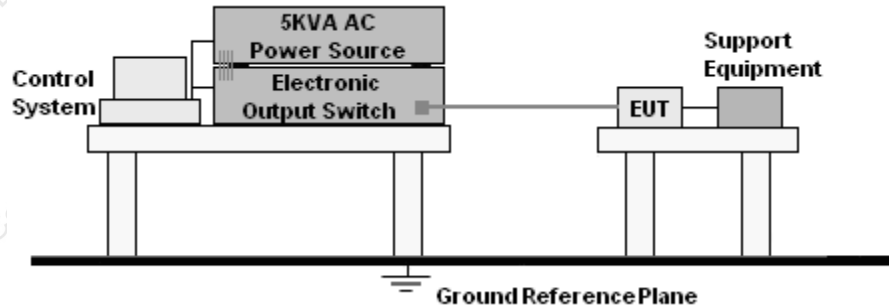

**15.2 Test Standard**

EN 61000-6-2, EN 61000-4-11

**15.3 Severity Levels and Performance Criterion**

Input and Output AC Power Ports.

- Voltage Dips.
- Voltage Interruptions.

Environmental Phenomena	Test Specification	Units	Performance Criterion
Voltage Dips	100 0.5	% Reduction period	C
	60 10	% Reduction period	C
	30 25	% Reduction period	C
Voltage interruptions	100 250	% Reduction period	C

**15.4 Test Procedure**

- 1) Set up the EUT and test generator as shown on section 14.1
- 2) The interruption is introduced at selected phase angles with specified duration. There is a 3mins minimum interval between each test event.
- 3) After each test a full functional check is performed before the next test.
- 4) Repeat procedures 2 & 3 for voltage dips, only the level and duration is changed.
- 5) Record any degradation of performance.

**15.5 Test Result**

The EUT is powered by DC, no requirements for this item.



### 16.SETUP PHOTOGRAPHS

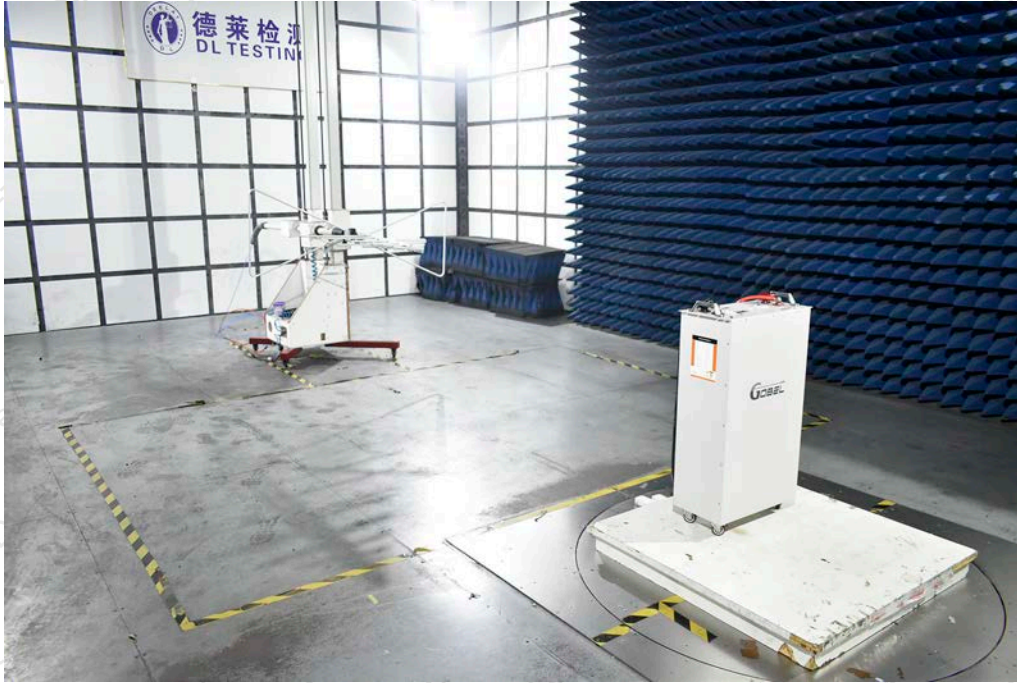



### 17.EUT PHOTOGRAPHS





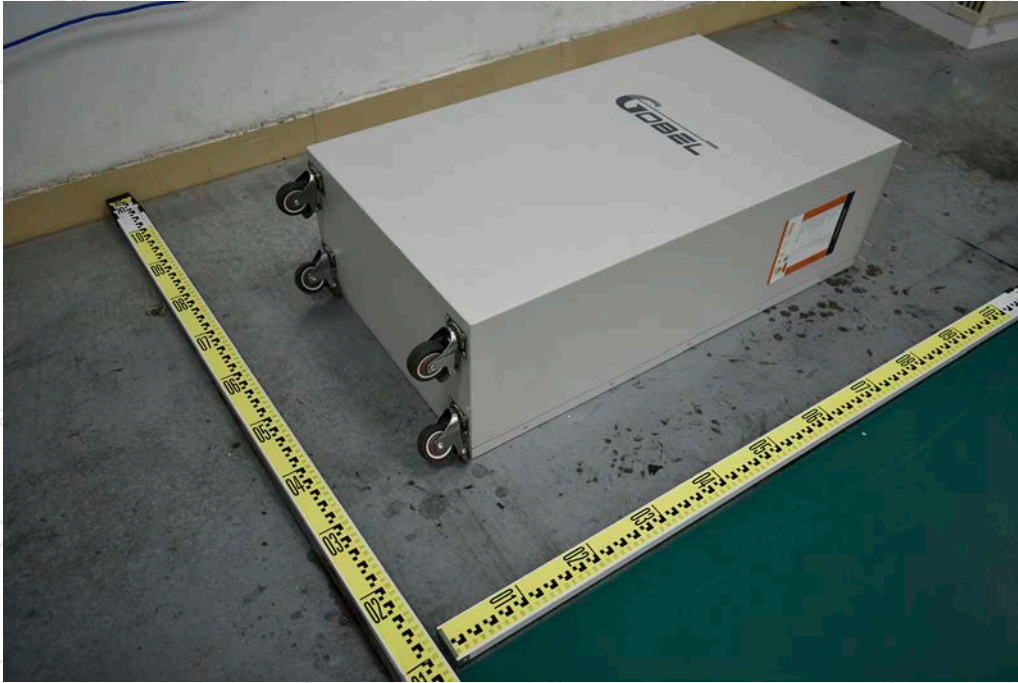

\*\*\*\*\* END OF REPORT \*\*\*\*\*