	楚能新能源股份有限公司	文件编号	C-PS-0004
		文件版次	D
		文件页次	1/17

产品规格书
Product Specification
磷酸铁锂储能电池
LFP Cell for ESS

容量 Capacity: 100Ah

型号 Model: PF160-100A

料号 Mode: B201A10007

制定/研究院 Prepared by /the Research Institute	批准/研究院 Approved by /the Research Institute	批准/销售 Approved by/ the sales Dept.	批准/品质 Approved by/Quality Dept.	批准/产品经理 Approved by/the Product Manager
林定文	闻寅	杨标	高亚果	朱旭

公司地址：湖北省孝感市临空经济区楚能大道特 1 号
Address: NO.1, Cornex Avenue, Linkong Economic Zone, Xiaogan, Hubei

	楚能新能源股份有限公司	文件编号	C-PS-0004
		文件版次	D
		文件页次	3/17

目 录 Content

1	适用范围 SCOPE OF APPLICATION.....	4
2	产品基本参数 BASIC PARAMETERS OF THE PRODUCT.....	4
3	标准测试条件 STANDARD TEST CONDITIONS.....	7
4	电池性能参数 CELL PERFORMANCE PARAMETERS.....	11
4.1	电性能参数 Electrichemical Performance Parameters.....	11
4.2	安全性能参数 Safety Performance Parameters.....	12
5	电池外形尺寸 CELL APPEARANCE DIMENSIONS.....	14
6	标志、包装、运输、贮存 LABEL, PACKING, TRANSPORTATION, STORAGE.....	15
6.1	标志 Label.....	15
6.2	包装 Package.....	15
6.3	运输 Transportation.....	16
6.4	贮存 Storage.....	16
7	安全及警告 SAFETY AND WARNINGS.....	16
8	产品寿命终止管理 END OF LIFE MANAGEMENT.....	17

	楚能新能源股份有限公司	文件编号	C-PS-0004
		文件版次	D
		文件页次	4/17

1 适用范围 Scope of Application

本产品规格书规定了楚能新能源生产的 PF160-100A 方型铝壳磷酸铁锂储能电芯的性能规格和注意事项。

This product specification defines the performances and notes of the PF160-100A LFP cell for ESS produced by the Cornex.

2 产品基本参数 Basic Parameters of the Product

NO.	参数 Parameter	规格 Specification	条件 Condition
2.1	标称容量 Nominal capacity	$\geq 100\text{Ah}$	参照 3.3 标准充放电测试 Reference to paragraph 3.3 standard charge and discharge procedure.
2.2	标称能量 Nominal energy	$\geq 320\text{Wh}$	参照 3.4 标准充放电测试 Reference to paragraph 3.4 standard charge and discharge procedure.
2.3	工作电压 Operating voltage	2.5~3.65V 2.0~3.65V	$T > 0^{\circ}\text{C}$ $T \leq 0^{\circ}\text{C}$
2.4	电池内阻 Impedance (1KHz)	$\leq 0.40\text{m}\Omega$	新电池 20%SOC Fresh cell 20%SOC
2.5	最大持续充电电流 Maximum continuous charging current	不允许充电 not allowed to charge	$< 0^{\circ}\text{C}$
		$\leq 15\text{A}$ (0.15C)	$0^{\circ}\text{C} \leq \text{温度 } T < 10^{\circ}\text{C}$
		$\leq 50\text{A}$ (0.5C)	$10^{\circ}\text{C} \leq \text{温度 } T < 20^{\circ}\text{C}$
		$\leq 100\text{A}$ (1.0C)	$20^{\circ}\text{C} \leq \text{温度 } T < 45^{\circ}\text{C}$
		$\leq 50\text{A}$ (0.5C)	$45^{\circ}\text{C} \leq \text{温度 } T \leq 60^{\circ}\text{C}$
		不允许充电 not allowed to charge	$> 60^{\circ}\text{C}$

	楚能新能源股份有限公司	文件编号	C-PS-0004
		文件版次	D
		文件页次	5/17

2.6	最大持续放电电流 Maximum continuous discharge current	150A (1.5C)	25±2°C
2.7	最大脉冲放电电流 Maximum pulse discharge current	300A (3.0C)	25±2°C, 50% SOC, 30s
2.8	工作温度 (充电) Operating temperature. (charge)	0~60°C	N.A.
2.9	工作温度 (放电) Operating temperature (discharge)	-30~60°C	N.A.
2.10	持续工作最适温度 Continuous operating Temp	10~35°C	在这个条件下工作的电池能确保其设计性能 Ensure its design performance under this condition.
2.11	存储温度 Storage Temp	可存储温度 Allowed storage temperature: -30~60°C	存储环境湿度≤75%ROH 无凝露 Storage ambient humidity ≤75% ROH, no condensation.
		最佳存储温度范围 Optimal storage temperature range: 10~35°C	
2.12	电池重量 Cell Weight	2.0±0.1kg	N.A.
2.13	电池尺寸 Typical dimensions (W*H*T)	厚度(Thickness): 50.0±0.5mm 宽度(Height): 160.1±0.5mm (非折角处, 仅作参考); 160.6±0.5mm (折角处); 肩高(Shoulder height): 116.0±0.5mm 总高(Total height): 118.5±0.5mm	厚度在 SOC ≤30% 300±10kgf 压力下测试得到, 电池为新鲜电池 Thickness with compression force SOC ≤30% and (300±10kgf), BOL.

	楚能新能源股份有限公司	文件编号	C-PS-0004
		文件版次	D
		文件页次	6/17

2.14	外观 Appearance	<p>外观上无深划痕，裂缝，锈蚀，污点或泄露等影响电池商业价值的缺陷</p> <p>There is no deep scratch, crack, rust, stain or leakage on the appearance, which affects the commercial value of the cell.</p>	N.A.
2.15	循环寿命 Cycle life	<p>≥4500 cycles (100%DOD 80%EOL)</p>	<p>在 25°C±2°C条件下，BOL 电池预紧力 300±10kgf，参照 3.4 标准充放电测试，容量保持率≥80%</p> <p>25±2°C under 300±10kgf preload, BOL. Reference to paragraph 3.4 standard charge and discharge procedure. Capacity retention≥80%</p>
		<p>≥6000 cycles (90%DOD 70%EOL)</p>	<p>在 25°C±2°C条件下，BOL 电池预紧力 300±10kgf，参照 3.5 标准充放电测试，容量保持率≥70%</p> <p>25±2°C under 300±10kgf preload, BOL. Reference to paragraph 3.5 standard charge and discharge procedure. Capacity retention≥70%</p>
2.16	<p>25°C满电存储 25°C fully charged storage</p>	<p>荷电保持率≥95% 初始容量 Capacity retention≥95% initial capacity 容量恢复率≥97% 初始容量 Capacity recovery≥97% initial capacity</p>	<p>在 25°C±2°C条件下，参照 3.1 标准充电至 100%SOC 存 28 天，参照 3.2 标准放电，再参照 3.3 标准充放电</p> <p>25±2°C, reference to paragraph 3.1 standard charge to 100% SOC storage for 28 days, reference to paragraph 3.2 standard discharge, then reference to paragraph 3.3 standard charge and discharge procedure.</p>

	楚能新能源股份有限公司	文件编号	C-PS-0004
		文件版次	D
		文件页次	7/17

2.17	55°C满电存储 55°C fully charged storage	荷电保持率≥95% 初始容量 Capacity retention≥95% initial capacity 容量恢复率≥97% 初始容量 Capacity recovery≥97% initial capacity	在 55°C±2°C条件下，参照 3.1 标准充电至 100%SOC 存 7 天，参照 3.2 标准放电，再参照 3.3 标准充放电 55±2°C, reference to paragraph 3.1 standard charge to 100% SOC storage for 7 days, reference to paragraph 3.2 standard discharge, then reference to paragraph 3.3 standard charge and discharge procedure.
2.18	45°C半电存储 45°C half charged storage	容量恢复率≥95% 初始容量 Capacity recovery≥95% initial capacity	在 45°C±2°C条件下，参照 3.1 标准充电至 50%SOC 存 28 天,参照 3.3 标准充放电 45±2°C, reference to paragraph 3.1 standard charge to 50% SOC storage for 28 days, reference to paragraph 3.3 standard charge and discharge procedure.
2.19	应用海拔 Altitude	≤2000m	N.A.

3 标准测试条件 Standard Test Conditions

NO.	参数 Parameter	规格 Specification	条件 Condition
3.1	标准充电 Standard charge	0.5C 恒流恒压充电至 3.65V，截止电流 0.05C 0.5C constant current and constant voltage charge to 3.65 V, cut-off current 0.05C.	25±2°C
3.2	标准放电 Standard discharge	1C 恒流放电至 2.5V 1C constant current discharge to 2.5 V.	25±2°C

	楚能新能源股份有限公司	文件编号	C-PS-0004
		文件版次	D
		文件页次	8/17

3.3	标准充放电 Standard charge and discharge	0.5C 恒流恒压充电至 3.65V，截止电流 0.05C；静置 30min；1C 恒流放电至 2.5V 0.5C constant current and constant voltage charge to 3.65 V, cut-off current 0.05C, rest 30min, 1C constant current discharge to 2.5 V.	25±2°C
3.4	标准循环充放电 (100%DOD) Standard cycle charge and discharge (100%DOD)	0.5C 恒流恒压充电至 3.65V，截止电流 0.05C；静置 30min；0.5C 恒流放电至 2.5V 0.5C constant current and constant voltage charge to 3.65 V, cut-off current 0.05C, rest 30min, 0.5C constant current discharge to 2.5 V.	25±2°C
3.5	标准循环充放电 (90%DOD) Standard cycle charge and discharge (90%DOD)	0.5C 恒流充电至 3.48V；静置 30min；0.5C 恒流放电至 2.9V 0.5C constant current charge to 3.48 V, rest 30min, 0.5C constant current discharge to 2.9 V.	25±2°C
3.6	其它放电 Other discharge	0.5C 恒流放电至 2.5V 0.5C constant current discharge to 2.5 V. 1C 恒流放电至 2.0V 1C constant current discharge to 2.0 V.	T>0°C T≤0°C

	楚能新能源股份有限公司	文件编号	C-PS-0004
		文件版次	D
		文件页次	9/17

<p>3.7</p>	<p>倍率充电 Rate charge</p>	<p>1.0C 放电至 2.5V; 搁置 30min; 0.5C 恒流恒压充至 3.65V, 截止电流 0.05C, 搁置 30min; 1C 恒流放电至 2.5V, 搁置 30min; 0.5C 恒流充电至 3.65V, 静置 30min; 1C 恒流放电至 2.5V, 搁置 30min, 记录放电容量 C0.5; 1C 恒流充至 3.65V, 搁置 30min; 1C 恒流放电至 2.5V, 搁置 30min, 记录放电容量 C1; 2C 恒流充至 3.65V, 搁置 60min; 1C 恒流放电至 2.5V, 搁置 30min, 记录放电容量 C2; 1C constant current discharge to 2.5 V, rest 30min. 0.5C constant current and constant voltage charge to 3.65 V, cut-off current 0.05C, rest 30min, 1C constant current discharge to 2.5 V, rest 30min. 0.5C constant current charge to 3.65 V, rest 30min, 1C constant current discharge to 2.5 V, rest 30min, and record the discharge capacity as C0.5. 1C constant current charge to 3.65 V, rest 30min, 1C constant current discharge to 2.5 V, rest 30min, and record the discharge capacity as C1. 2C constant current charge to 3.65 V, rest 60min, 1C constant current discharge to 2.5 V, rest 30min, and record the discharge capacity as C2.</p>	<p>25±2°C</p>
------------	-----------------------------	---	---------------

	楚能新能源股份有限公司	文件编号	C-PS-0004
		文件版次	D
		文件页次	10/17

<p>3.8</p>	<p>倍率放电 Rate discharge</p>	<p>1.0C 放电至 2.5V; 搁置 30min; 0.5C 恒流恒压充至 3.65V, 截止电流 0.05C, 搁置 30min; 0.5C 恒流放电至 2.5V, 搁置 30min; 充放电循环 3 次, 以第 3 次放电容量为初始容量; 0.5C 恒流恒压充至 3.65V, 截止电流 0.05C, 搁置 30min; 0.5C 恒流放电至 2.5V, 搁置 30min; 0.5C 恒流恒压充至 3.65V, 截止电流 0.05C, 搁置 30min; 1.0C 恒流放电至 2.5V, 搁置 30min; 0.5C 恒流恒压充至 3.65V, 截止电流 0.05C, 搁置 30min; 2.0C 恒流放电至 2.5V, 搁置 60min; 0.5C 恒流恒压充至 3.65V, 截止电流 0.05C, 搁置 30min; 3.0C 恒流放电至 2.5V, 搁置 30min; 1C constant current discharge to 2.5 V, rest 30min; 0.5C constant current and constant voltage charge to 3.65 V, cut-off current 0.05C, rest 30min, 0.5C constant current discharge to 2.5 V, rest 30min; Charge and discharge cycle for 3 times, based on the data of the third week. 0.5C constant current and constant voltage charge to 3.65 V, cut-off current 0.05C, rest 30min, 0.5C constant current discharge to 2.5 V, rest 30min; 0.5C constant current and constant voltage charge to 3.65 V, cut-off current 0.05C, rest 30min, 1C constant current discharge to 2.5 V, rest 30min; 0.5C constant current and constant voltage charge to 3.65 V, cut-off current 0.05C, rest 30min, 2C constant current discharge to 2.5 V, rest 60min; 0.5C constant current and constant voltage charge to 3.65 V, cut-off current 0.05C, rest 30min, 3C constant current discharge to 2.5 V, rest 30min;</p>	<p>25±2°C</p>
------------	--------------------------------	---	---------------

	楚能新能源股份有限公司	文件编号	C-PS-0004
		文件版次	D
		文件页次	11/17

4 电池性能参数 Cell Performance Parameters

4.1 电性能参数 Electricchemical Performance Parameters

NO.	项目 Project	参数 Parameter	规格 Specification	条件 Condition
4.1.1	高低温放电性能 High and low temperature capacity	55°C放电容量 Discharge capacity@55°C	≥99.5%	新电池在 25°C±2°C条件下, 参照 3.1 标准充电, 在 55±2°C条件下静置 5h, 参照 3.2 标准放电 Fresh cell 25°C±2°C, reference to paragraph 3.1 standard charge procedure, 55°C±2°C, rest for 5h, reference to paragraph 3.2 standard discharge procedure.
4.1.2		-20°C放电容量 Discharge capacity@-20°C	≥85%	BOL 电池在 25°C±2°C条件下, 参照 3.1 标准充电, 在 -20±2°C条件下静置 16h 后, 参照 3.6 标准放电 BOL cell 25°C±2°C, reference to paragraph 3.1 standard charge procedure, -20°C±2°C, rest for 16h, reference to paragraph 3.6 standard discharge procedure.
4.1.3	倍率充电性能 Rate charge performance	放电容量 C1/放电容量 C0.5 Discharge capacity C1 / discharge capacity C0.5	≥95%	在 25°C±2°C条件下, 参照 3.7 标准充放电 25±2°C, Reference to paragraph 3.7 standard charge and discharge procedure.
		放电容量 C2/放电容量 C0.5 Discharge capacity C2 / discharge capacity C0.5	≥90%	

	楚能新能源股份有限公司	文件编号	C-PS-0004
		文件版次	D
		文件页次	12/17

4.1.4	倍率放电性能 Rate discharge performance	1C 放电容量/0.5C 放电容量 1C discharge capacity / 0.5C discharge capacity	≥98%	在 25°C±2°C条件下, 参照 3.8 标准充放电 25±2°C, Reference to paragraph 3.8 standard charge and discharge procedure.
		2C 放电容量/0.5C 放电容量 2C discharge capacity / 0.5C discharge capacity	≥95%	
		3C 放电容量/0.5C 放电容量 3C discharge capacity / 0.5C discharge capacity	≥90%	
4.1.5	充放电能效 Charge and discharge energy efficiency	0.5C 放电能量/0.5C 充电能量 0.5C discharge energy / 0.5C charge energy	≥94%	在 25°C±2°C条件下, 参照 3.4 标准充放电循环 3 次, 以第 3 周数据为准 Reference to paragraph 3.4 standard charge and discharge cycle for 3 times, based on the data of the third week.

4.2 安全性能参数 Safety Performance Parameters

No.	参数 Parameter	规格 Specification	条件 Condition
4.2.1	过充电 Over charge	不爆炸, 不起火 No fire, no explosion.	测试方法参照 GB/T 36276-2018《电力储能用锂离子电池》 A.2.12 Reference to the GB/T 36276-2018 Lithium ion batteries for electric energy storage A.2.12
4.2.2	强制放电 Forced discharge	不爆炸, 不起火 No fire, no explosion.	测试方法参照 UN38.3 T.8 Reference to the UN38.3 T.8

	楚能新能源股份有限公司	文件编号	C-PS-0004
		文件版次	D
		文件页次	13/17

4.2.3	过放电 Over discharge	不爆炸，不起火 No fire, no explosion.	测试方法参照 GB/T 36276-2018《电力储能用锂离子电池》 A.2.13 Reference to the GB/T 36276-2018 Lithium ion batteries for electric energy storage A.2.13
4.2.4	短路 Short circuit	不爆炸，不起火 No fire, no explosion.	测试方法参照 GB/T 36276-2018《电力储能用锂离子电池》 A.2.14 Reference to the GB/T 36276-2018 Lithium ion batteries for electric energy storage A.2.14
4.2.5	内短路 Internal short-circuit	不爆炸，不起火 No fire, no explosion.	测试方法参照 IEC62619 7.3.2 Reference to the IEC62619 7.3.2
4.2.6	挤压 Crush	不爆炸，不起火 No fire, no explosion.	测试方法参照 GB/T 36276-2018《电力储能用锂离子电池》 A.2.15 Reference to the GB/T 36276-2018 Lithium ion batteries for electric energy storage A.2.15
4.2.7	跌落 Drop	不爆炸，不起火 No fire, no explosion.	测试方法参照 GB/T 36276-2018《电力储能用锂离子电池》 A.2.16 Reference to the GB/T 36276-2018 Lithium ion batteries for electric energy storage A.2.16
4.2.8	低气压 Altitude simulation	不爆炸，不起火， 不漏液 No fire, no explosion, no electrolyte leakage	测试方法参照 GB/T 36276-2018《电力储能用锂离子电池》 A.2.17 Reference to the GB/T 36276-2018 Lithium ion batteries for electric energy storage A.2.17
4.2.9	加热 Heating	不爆炸，不起火 No fire, no explosion.	测试方法参照 GB/T 36276-2018《电力储能用锂离子电池》 A.2.18 Reference to the GB/T 36276-2018 Lithium ion batteries for electric energy storage A.2.18

	楚能新能源股份有限公司	文件编号	C-PS-0004
		文件版次	D
		文件页次	14/17

4.2.10	热失控 Thermal runaway	不爆炸，不起火 No fire, no explosion	测试方法参照 GB/T 36276-2018《电力储能用锂离子电池》 A.2.19 Reference to the GB/T 36276-2018 Lithium ion batteries for electric energy storage A.2.19
4.2.11	抛射 Projectile	无抛射 No projectile	测试方法参照 UL1973 E11.10 Reference to the UL1973 E11.10
4.2.12	温度循环 Temperature cycle	不爆炸，不起火 No fire, no explosion.	测试方法参照 UN38.3 T.2 Reference to the UN38.3 T.2
4.2.13	振动 Vibrating	不起火、不爆炸、 不漏液 No fire, no explosion, no electrolyte leakage	测试方法参照 UN38.3 T.3 Reference to the UN38.3 T.3
4.2.14	加速度冲击 Acceleration shock	不起火、不爆炸、 不漏液 No fire, no explosion, no electrolyte leakage	测试方法参照 UN38.3 T.4 Reference to the UN38.3 T.4
4.2.15	撞击 Impact	不爆炸，不起火 No fire, no explosion.	测试方法参照 IEC 62619 7.2.2 Reference to the IEC 62619 7.2.2
4.2.16	针刺 Nail Penetration	不爆炸，不起火 No fire, no explosion	测试方法参照 GB/T 31485-2015 《电动汽车用动力蓄电池安全要求及试验方法》 6.2.8 Reference to the GB/T 31485-2015 Electric vehicles traction battery safety requirements and test methods 6.2.8

5 电池外形尺寸 Cell Appearance Dimensions

	楚能新能源股份有限公司	文件编号	C-PS-0004
		文件版次	D
		文件页次	15/17

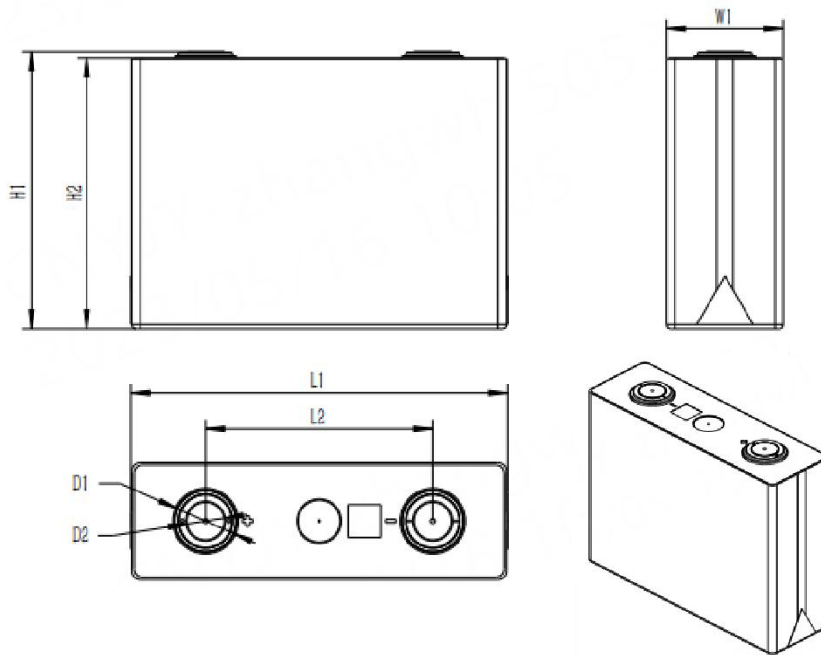

序号 No.	项目 Item	尺寸 (mm) Dimensions
1	宽度 L1	160.1±0.5 (非折角处, 仅作参考) 160.6±0.5 (折角处)
2	极柱中心距 L2	97.0±0.3
3	总高 H1	118.5±0.5
4	肩高 H2	116.0±0.5
5	厚度 W1	50.0±0.5
6	极柱外径 D1	26.7±0.2
7	极柱内径 D2	16.0±0.2

注：电芯厚度尺寸 W1：SOC≤30%，300±10kgf 条件下进行测试

Notes: Thickness (W1) test condition: SOC≤30%, under 300±10kgf.

6 标志、包装、运输、贮存 Label, Packing, Transportation, storage

6.1 标志 Label

每个产品上应有清晰的二维码。

Each product should have a clear QR code on it.

6.2 包装 Package

产品有外包装，保证产品在运输、装卸、堆放过程中不受机械损伤。

	楚能新能源股份有限公司	文件编号	C-PS-0004
		文件版次	D
		文件页次	16/17

The product has outer packages to ensure that the product is not mechanically damaged during transportation, loading, unloading and stacking.

6.3 运输 Transportation

在运输过程中应严禁暴力装卸，防止剧烈振动、冲击或挤压，防止日晒雨淋。

During transportation, violent loading and unloading should be strictly prohibited, to prevent server vibration, impact or squeeze, and to prevent from the sun and rain.

6.4 贮存 Storage

产品应贮存在环境温度为-30°C~60°C，相对湿度≤75%的清洁、干燥、通风的库房内，库房内不应含有腐蚀性气体；产品应远离火源和热源（不得少于 2m）。

The product should be stored in a clean, dry and ventilated warehouse with an ambient temperature of -30°C~60°C and a relative humidity of ≤75%. The warehouse should not contain corrosive gases; the product should be away from fire and heat sources (not less than 2 meters).

建议电芯在 30%~50% SOC 下存储。电芯长期不使用时，每三个月进行一次充放电，并补电至 30%~50% SOC，以免电芯过放，影响性能。

It is recommended that the cell should be stored at 30% to 50% SOC. When the cell is not used for a long time, you should charge and discharge it every three months, and charge to 30%~50% SOC to avoid over discharge and to avoid affecting its performance.

7 安全及警告 Safety and Warnings

7.1 在使用之前，应仔细阅读规格书。

Before operating the cell, you should read the specifications in detail.

7.2 禁止将电芯浸入水中或者其它导电性液体中。

Do not immerse the cell into water or other conductive liquids.

7.3 禁止将电芯投入火中或者长期暴露电芯工作范围外的温度中，电芯温度不能超过 60°C，如果电芯中电芯温度超过 60°C，停止电芯运行。

It is forbidden to put the cell into fire or expose it to the environment beyond its working temperature range for a long time. If the working temperature of the cell exceeds 60°C, stop its operation!

7.4 严格按照标示和说明连接电芯正负极，禁止反向充电。

Connect the positive and negative poles of the cell strictly in accordance with the signs and instructions. No reverse charging!

7.5 当电解液泄漏时，应避免皮肤和眼睛接触电解液。如有接触，应使用大量的清水清洗接触到的区域并向医

	楚能新能源股份有限公司	文件编号	C-PS-0004
		文件版次	D
		文件页次	17/17

生寻求帮助。禁止任何人或动物吞食电芯的任何部件或电芯所含物质。

When the electrolyte leaks, your skin and eyes should be far away from the electrolyte. In case of contacting, you should wash your skin and eyes with plenty of water and seek medical advice. It is forbidden for any person or animal to swallow any part of the cell or the substance contained in the cell.

7.6 尽力保护电芯，使其免受机械振动、碰撞及压力冲击，否则电芯内部可能短路，产生高温或火灾。

You should protect the cell from mechanical vibration, collision and pressure impact, otherwise the cell might be short-circuited, thus causing high temperature or fire.

7.7 严禁使电芯承受过重的机械冲击。

The cell is strictly forbidden to subject excessive mechanical shock.

7.8 严禁使用过程中发生挤压、跌落、短路、漏液及其他不正常问题的电芯。

Squeeze, drop, short circuit, leakage and other abnormal problems are strictly forbidden during cell operation.

7.9 在使用过程中严禁各电芯之间外壳直接接触或通过导体连接在一起形成通路。

During the operation of the cell, it is strictly forbidden to contact the cover of cells directly or connect them together via conductors to form a circuit.

7.10 电芯应该在远离静电的场所进行存储、使用。

Cells should be stored and used in a place away from static electricity.

7.11 在使用、充放电或者存储过程中发现电芯急剧变热、散发气味、变色、变形或者其他反应，应立即停止使用，并进行相应的处理。

During operation, charge, discharge or storage, if the cell suddenly heats-up, emits odor, discolors, deforms or has other reactions, it should be stopped immediately and treated accordingly.

8 产品寿命终止管理 End of life management

为了确保电芯的安全应用，客户需要建立有效的跟踪系统监测并记录每个电芯的电压、内阻，电芯容量衰减的测量方法和计算方法需要客户和本企业共同讨论和双方同意，当使用电芯的容量衰减到初始容量的80%时应停止使用电芯，违反该项要求，将免除本企业依据产品销售协议以及本规格书所应承担的产品质量保证责任。

For the sake of the security operation of the cell, the clients should establish an effective tracking system to monitor and record the voltage and internal resistance of each cell. The measurement and calculation methods should be discussed and commonly agreed by the clients and the Cornex when the capacity of the cell decays to 80% of the initial capacity, and the use of the cell can't be operated. Otherwise, our enterprise will not bear the product quality assurance responsibilities based on the product sales agreement and this specification.