

Document #:

Rev: 1.0

Type: Product Specification of 315Ah Cell

型号:315Ah 产品规格书

315Ah 产品规格书

Product Specification of 315Ah Cell

电芯型号 Cell Model: HC-L315A 3.2V 315Ah 1008Wh电芯容量 Cell Capacity: 315Ah

电芯设计	销售审批	质量审批	项目经理审批
王进	徐有斌	王强	柯唯

修改记录

AMENDMENT RECORDS

Rev.	ECN No.	Effective Date	Author	Description of Revision
1.0		2024/1/27	Jin Wang	New release

目录 Content

0. 术语定义 Definitions	4
1. 适用范围 Scope of application	6
2. 产品参数 Product Parameters	6
2.1 概要 Abstract.....	6
2.2 产品图纸 Mechanical Drawing.....	8
2.3 充电模式/参数 Charging Mode/Parameters	8
2.4 放电模式/参数 Discharging Mode/Parameters.....	9
2.5 极柱和 Busbar 焊接参数 Welding parameters of post terminal and busbar.....	10
2.6 电芯温升 Cell temperature rise.....	10
2.7 安全和可靠性 Safety and reliability	11
3. 产品寿命终止管理 Product end of life management	11
4. 应用条件 Application conditions.....	11
5. 安全防范 Safety Precautions	14
6. 免责声明 Disclaimer.....	16

0. 术语定义 Definitions

术语 Terms	定义 Definitions
产品 Product	本技术协议中的“产品”是指 AESC 生产的 HC-L315A 3.2V 315Ah 1008Wh 储能用磷酸铁锂电池。 Means the HC-L315A 3.2V 315Ah 1008Wh ESS LFP cells produced by AESC
客户 Customer	指《AESC 产品销售合同》中的买方 Means the customer in the «AESC product sales contract»
AESC	远景动力技术有限公司 Envision Dynamics Technology Co., Ltd
物料编码 PN	为了区别电池应用于不同的使用区域或不同的应用条件下，AESC 为 HC-L315A 3.2V 315Ah 1008Wh 储能用磷酸铁锂电池定义的物料编号。 Means the unique part number provided by AESC to identify the HC-L315A 3.2V 315Ah 1008Wh ESS LFP cells supplied by AESC.
环境温度 Ambient Temperature	电池所处的周围环境温度。 Means the ambient temperature of the environment which the products are exposed to.
电池管理系统 Battery Management System(BMS)	客户用于监测和记录产品在整个服务期限内的运行参数的一种有效的追踪和控制系统。其追踪和记录的参数包括但不限于电压、电流、温度等，以控制产品的运行并确保产品运行环境及运行条件符合本技术协议的规定。 Means an active tracking and control system used by the customer to monitor and record the operating parameters, including but not limited to voltage, current and temperature, of each product in its entire service life, and to control the operation of each product to ensure. that the product operating environment and operating conditions comply with the provisions of this technical agreement.
电芯温度 Cell Temperature	由接入电池的温度传感器测量的电芯顶盖温度，可通过采集温度（如极柱温度）修正为顶盖温度。 Means the temperature of the cell measured by the temperature sensor connected to the

术语 Terms	定义 Definitions
	main part of cell. The temperature can be calculated from the collected temperature (Such as pole temperature) .
新电池状态 Fresh State	在规定的运输条件下，客户收货 7 天内且循环次数少于 3 次的电池状态。 Means the cell status within 7 days of customer receipt and with less than 3 cycles under certain shipping conditions.
充电倍率 C- rate	充电功率与电池标准能量的比率。 The ratio of charging power to the standard energy of cells.
放电倍率 D- rate	放电功率与电池标准能量的比率。 The ratio of discharging power to the standard energy of cells.
循环 Cycle	电池按标准充放电模式充放一次为一个循环。 Means a state when a total of charge and discharge according to the standard charge and discharge method
生产日期 Production date	电池的生产日期，每个电池的顶端刻码上标示的明确的日期代码为生产日期。 Means the production date of the cell marking on the top of the cell by date code.
荷电状态 SOC	电池实际充电量与满充电量的比值，表征电池的充电状态。100%SOC 表示电池满充到 3.65V，0%SOC 表示电池完全放电到 2.5V。 Means the ratio of the actual battery charge to the full charge, characterizing the state of charge of the battery. The state of charge of 100% SOC indicates that the battery is fully charged to 3.65V, and the state of charge of 0% SOC indicates that the battery is completely discharged to 2.5V.
电芯温升 Cell temperature rise	在本技术协议规定的条件如充电过程或者放电过程中电芯温度的升高。 Means the cell temperature rises during the conditions specified in this document, such as the charging process or the discharging process.
测量单位 Units of measurement	电压单位“V” (Volt 伏特) ,Unit of voltage 电流单位“A” (Ampere 安培) ,Unit of current 电荷单位“Ah” (Ampere-Hour 安培-小时) ,Unit of electric charge

术语 Terms	定义 Definitions
	能量单位“Wh” (Watt-Hour 瓦特-小时) ,Unit of energy 电阻单位“mΩ” (MilliOhm 毫欧) ,Unit of resistance 温度单位“°C” (Celsius degree 摄氏度) ,Unit of temperature 长度单位“mm” (millimeter 毫米) ,Unit of length 时间单位“s” (second 秒) ,Unit of time 频率单位“Hz” (Hertz 赫兹) ,Unit of frequency

1. 适用范围 Scope of application

本技术协议详细描述了 AESC 生产的 HC-L315A 3.2V 315Ah 1008Wh 储能用磷酸铁锂电池的产品性能指标以及产品使用条件及风险警示。

This document specifies the performance indicators, conditions of use, and cautions of HC-L315A 3.2V 315Ah 1008Wh ESS LFP cells supplied by AESC.

2. 产品参数 Product Parameters

2.1 概要 Abstract

No.	参数 Parameter	产品规格 Specification	条件 Condition
2.1.1	标准容量 Standard capacity	315Ah	新鲜电池, 参考 2.3 与 2.4 标准充放电模式测试 Fresh cell, Refer to 2.3&2.4 standard charge and discharge procedure
2.1.2	标准能量 Standard Energy	1008Wh	新鲜电池, 参考 2.3 与 2.4 标准充放电模式测试 Fresh cell, Refer to 2.3&2.4 standard charge and discharge procedure
2.1.3	工作电压 Operating voltage	2.5~3.65V (T>0°C) 2.0~3.65V (T≤0°C)	N.A.
2.1.4	电池内阻 Impedance(1KHz)	0.17±0.05mΩ	AC Impedance, 1000 Hz
2.1.5	出货容量 Shipping capacity	78.8±1Ah	~25% SOC

No.	参数 Parameter	产品规格 Specification	条件 Condition
2.1.6	月自放电 Residual capacity loss per month	≤2.0%	出货 SOC, 25±2°C储存 Shipping SOC, 25±2°C storage
2.1.7	充电温度 Charge Temp.	0~60°C	参考第 2.3 节 Refer to paragraph 2.2
2.1.8	放电温度 Discharge Temp.	-30~60°C	参考第 2.4 节 Refer to paragraph 2.3
2.1.9	电池重量 Cell Weight	5.65±0.30Kg	N.A.
2.1.10	存储温度 Storage Temp.	-30~60°C	存储环境湿度≤85%ROH, 无凝露 Storage ambient humidity ≤ 85% ROH, No condensation
2.1.11	电池尺寸 Cell dimension	厚度(Thickness): 71.80±0.60mm 宽度(Width): 174.26±0.60 mm 高度(Height): 207.01±0.60 mm	300±25Kgf 压力下, 含蓝膜, 高度包含极柱、底 盖, 新鲜电池 Thickness with compression force (300±25 Kgf), Blue film included, Height with Terminal and bottom cap, Fresh cell
2.1.12	储存 SOC Storage SOC	≥15%	无负载储存的 SOC 区间 Storage SOC interval without load
2.1.13	应用海拔 Altitude	<5000m	N.A.
2.1.14	循环次数 Cycle No.	≥8000 Cycles	25±2°C, 初始夹紧力 300± 25Kgf, 标准充放电 测试, 循环至标准容量的 70% At 25±2°C, cycle test by the standard charge and discharge method with 300±25Kgf preload, until 70% SOH

2.2 产品图纸 Mechanical Drawing

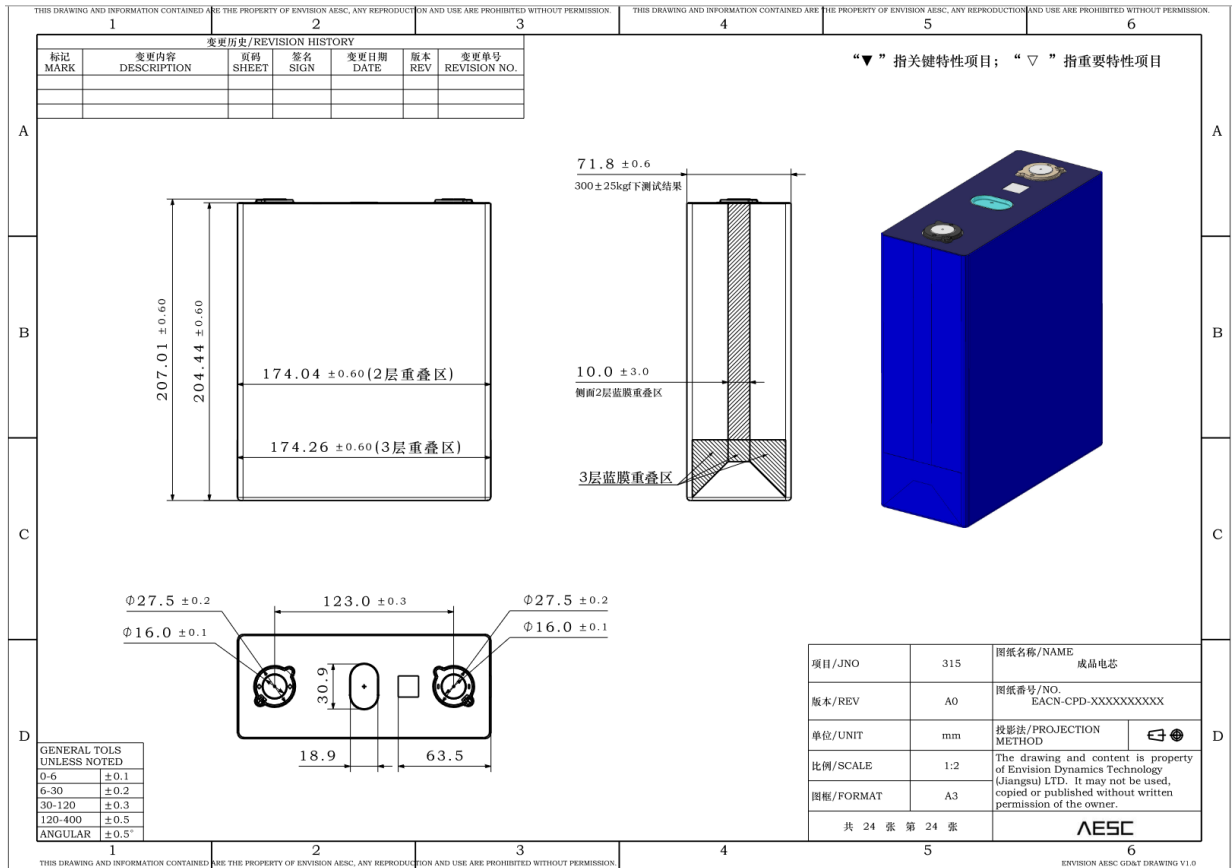

2.3 充电模式/参数 Charging Mode/Parameters

No.	参数 Parameter	产品规格 Specification	条件 Condition
2.3.1	标准充电功率 Standard charge Power	0.5P	25±2°C
2.3.2	最大可持续充电功率 Maximum charge power (continuous)	0.5P	25±2°C
2.3.3	标准充电电压 Standard charge voltage	3.65V	N.A.
2.3.4	标准充电温度 Standard charge temperature	25±2 °C	电芯温度 Cell Temperature
2.3.5	标准充电模式 Standard charge method	在 25±2° C 条件下, 0.5P 恒功率充电至 3.65V, 静置 30min。 At 25±2 °C, 0.5P constant power charge to 3.65 V, rest 30min.	
2.3.6	绝对充电温度 Absolute charging temperature	0~60°C	无论电芯处在何种充电模式, 一旦发现电芯温度超过绝对充电温度范围即停止充电

No.	参数 Parameter	产品规格 Specification	条件 Condition
			No matter what charge mode the battery is in, stop charging once the cell temperature exceeds absolute charge temperature range.
2.3.7	绝对充电电压 Absolute charging voltage	最大 3.65V Max 3.65V	无论电芯处在何种充电模式，一旦发现电芯电压超过绝对充电电压范围即停止充电 No matter what charge mode the battery is in, stop charging once the cell voltage exceeds absolute charge voltage.

2.3.8 其他充电条件(模式) C-Rate Other charge Condition (C-Rate)

电芯温度/°C Cell Temperature/°C		<0°C	0-15°C	15-20°C	20-45°C	45-60°C	>60°C
最大充电功率 (P) Max charge power(P)	0%~100%SOC	不允许 Not allowed	0.1P	0.25P	0.5P	0.5P	不允许 Not allowed

2.4 放电模式/参数 Discharging Mode/Parameters

No.	参数 Parameter	产品规格 Specification	条件 Condition
2.4.1	标准放电功率 Standard discharge Power	0.5P	25±2°C
2.4.2	标准放电模式 Standard discharge method	在 25±2° C 条件下，0.5P 恒功率放电至 2.5V，静置 30min。 At 25±2 °C, 0.5P constant power discharge to 2.5 V, rest 30min.	
2.4.3	最大可持续放电功率 (continuous)	1P	N.A.
2.4.4	放电截止电压 Discharge cut-off voltage	2.5V (T>0°C) 2.0V (T≤0° C)	N.A.
2.4.5	标准放电温度 Standard discharge temperature	25±2 °C	电芯温度 Cell Temperature
2.4.6	绝对放电温度 Absolute discharge temperature	-30~60°C	无论电芯处在持续放电模式或脉冲放电模式，若电芯温度超过绝对放电温度，则停止放电 Stop discharging once cell temperature is

No.	参数 Parameter	产品规格 Specification	条件 Condition
			outside this range regardless of whether continuous or pulse current is adopted.

2.4.7 其他放电条件(模式) D-Rate Other discharge Condition (D-Rate)

电芯温度/° C Cell Temperature/°C		<-30°C	-30-10°C	10-20°C	20-45°C	45-60°C	>60°C
最大充电功 (P) Max discharge power(P)	0%~100% SOC	不允许 Not allowed	0.5P	1P	1P	0.5P	不允许 Not allowed

2.5 极柱和 Busbar 焊接参数 Welding parameters of post terminal and busbar

No.序号	项目 Item	标准 Standard
1	熔深 Depth of fusion	0.5~1.5mm
2	熔宽 Width of fusion	≥0.8mm
3	拉拔力 Drawing force	≥600N
4	极柱塑胶件温度 Temperature of post terminal plastic parts	200°C last for <30s 200°C持续<30s
5	极柱承受压力 Pressure on post terminal	≤500N

2.6 电芯温升 Cell temperature rise

规格书中温升是指放电后的电池表面温度减去放电前的电池表面温度。电池温升的测量应在环境温度较为稳定且空间足够大的房间里进行。每个电池温度测量应选取经过校正的可以记录时间数据的温度感应器。

The temperature rise refers to the difference between the surface temperature of the cell after discharge and the surface temperature of the cell before discharge. The measurement of the temperature rise of the cell should be carried out in a room where the ambient temperature is relatively stable, and the space is large enough. For each cell temperature measurement, a calibrated temperature sensor that records time data should be selected.

参数 Parameter	产品规格 Specification	条件 Condition
持续充/放电温升 Continuous charge/discharge temperature rise	≤10°C	标准充/放电模式 Standard charge/discharge mode

2.7 安全和可靠性 Safety and reliability

2.7.1 使用条件说明：安全测试、寿命测试、系统成组设计需要施加预紧力，新鲜电芯的预紧力范围为 50kgf~800kgf，建议大面的预紧力控制公差为 ± 25 kgf。

Description of service conditions: safety test, cycle life test and pack design need to add preload force, and the range of preload force of fresh cell is 300kgf~800kgf, the recommended preload tolerance is ± 25 kgf.

2.7.2 产品在使用过程中会产生膨胀力，电芯在钢板测试条件下衰减至 65%时膨胀力约为 50000N，客户在产品的设计过程中需要考虑结构强度可靠性，建议电芯成组预留至少 1.5mm 的 Gap。

The cell will generate swelling force during attenuation. The swelling force of the cell at 65% SOH under the test condition of steel plate is about 50000N. The customer needs to consider the reliability of structural strength in the product design process. It is suggested that at least 1.5 mm Gap be reserved for the cell assembly to module.

3. 产品寿命终止管理 Product end of life management

电池的使用期限是有限的。客户应该建立有效的跟踪系统监测并记录每个使用期限内电池的内阻和容量。内阻以及容量的测量方法和计算方法需要客户和 AESC 共同讨论和双方同意。当使用中的电池的内阻超过这个电池最初内阻的 200%或容量小于等于初始容量 65%(25°C)，应停止使用电池。违反该项要求，将免除 AESC 依据产品销售协议以及本技术协议所应承担的产品质量保证责任。

This cell is designed to service with a finite lifetime. The customer shall develop and implement an active tracking system to monitor and record impedance and capacity of each product in its entire service life. AESC and its customer shall come into agreement about internal resistance and capacity measurement methods, AESC and/or its customer shall stop using any of the products when its resistance exceeds 200% of its internal resistance or its capacity fading to 65% of initial capacity@25°C. Failure to comply with this requirement shall render AESC's warranties under the contract inapplicable, thereby releasing AESC from any liability in connection therewith.

4. 应用条件 Application conditions

客户应当确保严格遵守以下与电池相关的应用条件：

Customer shall ensure that the following application conditions in connection with the products are strictly observed:

4.1. 客户应配置电池管理系统，严密监控、管理与保护每个电池。电芯初次使用必须进行小电流满充满放以激活，以保证后续使用中容量的充分发挥。

Customer shall procure that each product shall be used under the strict monitor, control and protection by the BMS. When the cell is first used, it must be fully charged and discharged by a small current for activating it and giving fully capacity.

4.2. 客户应保存完整的电池运转的监测数据，用作产品质量责任划分的参考。不具备完整的电池系统使用期限内的监测数据的，AESC 不承担产品质量保证责任。

Customer shall keep relevant records of the BMS monitoring data throughout the entire service life of each product, including keeping record of number of occurrences of charge, which could be used in the determination and judgment of any product warranty and liability claim entitlement. No warranty or liability claim should be considered without BMS diagnosis records (at a regular basis, esp. during maintenance) of the relevant product.

4.3. 电池管理系统需满足以下最基本的检测和控制要求

The BMS shall include the following monitoring and control features as a minimum requirement.

No.	Parameter 参数	Specification 产品规格	保护动作 Action
4.3.1	充电终止 Stop charging	<3.65V	充电终止电压应<3.65V，需考虑BMS的响应时间 The stop charging voltage should be less than 3.65V because of the BMS response time
4.3.2	第二级充电保护 Second charge protection	3.65V	当电池电压达到 3.65V，BMS 强制终止充电，且 BMS 应锁定直到技术人员解决问题 When the cell voltage reaches 3.65V, the BMS is forced to terminate charging, and the BMS should be locked until technicians solve the problem.
4.3.3	放电终止 Stop discharge	>2.5V(T>0°C) >2.0V(T≤0°C)	放电终止电压应>2.5V(T>0°C)或>2.0V(T≤0°C)，需考虑BMS的响应时间 The stop discharging voltage should be more than 2.5V(T>0°C)or 2.0V(T≤0°C) because of the BMS response time
4.3.4	第二级放电保护 Second discharge protection	2.5V(T>0°C) 2.0V(T≤0°C)	当电池电压达到 2.5V(T >0°C)或者2.0V(T≤0°C) 时，BMS 强制终止放电，且 BMS 应锁定直到技术人员解决问题 When the cell voltage reaches 2.5V(T >0°C) or 2.0V(T≤0°C), the BMS is forced to terminate discharging and should be locked until technicians solve the problem.
4.3.5	短路保护 Short circuit protection	不允许短路 No short circuit allowed	发生短路时，由过流保护装置断开电池 When a short circuit occurs, the cell is disconnected by the overcurrent protection device
4.3.6	过流保护	参考第 2.3和 2.4条	电池管理系统控制充放电电流符合规格

No.	Parameter 参数	Specification 产品规格	保护动作 Action
	Over current protection	Reference 2.3&2.4	Control discharge current by BMS to values within specification
4.3.7	过热保护 Overheat protection	参考第 2.3 和 2.4条 Reference 2.3&2.4	当温度超过本技术协议规定时，终止充电/放电 Stop charging and discharging when temperature exceeds specification
4.3.8	充电容量保护 Charging capacity protection	充电容量小于346.5Ah Charging capacity<346.5Ah	充电容量上限保护，充电容量小于标称容量的110% Charging capacity protection, charging capacity must be less than 110% of the nominal capacity
4.3.9	低温保护 Low temperature protection	充电：温度>0℃；放电：温度≥-30℃ Charging: T>0℃；Discharge: T≥-30℃	当温度低于规定时，终止充电/放电 Stop charging and discharging when temperature exceeds specification

备注：以上 No.4.3.1、4.3.2、4.3.3、4.3.4 为警示条款，提请客户注意：当电池达到上述任何一项条款描述的指标和参数状态时，意味着电池已超出本技术协议规定的使用条件，客户需依“保护动作”及本技术协议其他相关规定对电池采取保护措施，同时，AESC 声明对上述使用状态的电池质量不承担任何保证责任，并对因此而导致的客户及第三方的任何损失不予赔偿。

Note: The above No.4.3.1、4.3.2、4.3.3、4.3.4 are the warning clauses, draw the attention of customers: When the cell reaches any of the terms described in the above, means that the cell has been used beyond the specifications, the customer shall take protective measures on the cell in accordance with the "protection action" and other relevant provisions of this specification. At the same time, the AESC shall not take any responsibility for the damage in connection therewith, and no compensation shall be made for any loss caused by the customer and the third party.

4.4. 单体电池，建议补电周期为 6 个月，存储 SOC ≥ 15%，存储温度-30~30℃，存储过程中电芯电压需 > 3.2V。存储周期不考虑 BMS 或其他除单体电池以外的自耗电影响。

For cell, the recommended period to recharge is 3 months, the recommended SOC to storage is more than 15%, the recommended temperature to storage is between -30~30℃. The storage considers the self-discharge of cells only.

4.5. 电池避免在本技术协议禁止的低温条件下充电(包括标准充电，快充，紧急情况充电)，否则可能出现意外的容量降低现象。电池管理系统应依照最小的充电温度进行控制。禁止在低于本技术协议规定的温度条件下充电，否则 AESC 不承担质量保证责任。

Batteries should avoid charging at low temperature prohibited by this Technical Agreement (including standard charging, fast charging and emergency charging), otherwise accidental capacity reduction may occur. Battery

management system should be controlled according to the minimum charging temperature. It is forbidden to charge under the temperature lower than that stipulated in this technical agreement. Otherwise, AESC will not undertake the responsibility of quality assurance.

4.6. Pack 中应充分考虑电芯的散热问题，由于电箱散热设计问题导致的电芯或电池过热损坏，AESC 不承担质量保证责任。

The design of Pack must fully consider the heat dissipation problem of the cell. AESC does not take the responsibility due to the overheating of the cell or batteries caused by the thermal design problem of the Pack.

4.7. Pack 中应充分考虑电芯的防水、防尘问题，电箱必须满足 UL 和 IEC 有关标准规定的防水、防尘等级。由于防水、防尘问题而导致的电芯或电池的损坏（如腐蚀、生锈等），AESC 不承担质量保证责任。

The design of Pack must fully consider the waterproof and dustproof problems of the cells. The Pack must meet the waterproof and dustproof grade stipulated by the relevant standards of UL and IEC. The AESC does not take the responsibility due to damage to the cell or batteries (such as corrosion, rust, etc.) caused by water and dust.

4.8. 禁止不同 PN 料号电芯在同一电池系统中混用，否则，AESC 不承担质量保证责任。

It is forbidden to mix different PN batteries in the same battery system, otherwise, AESC will not be responsible for quality assurance.

5. 安全防范 Safety Precautions

5.1 禁止将电池浸入水中。

Do not immerse cells into water.

5.2 禁止将电池投入火中或长时间暴露在超过本技术协议第 2.1.7 条，第 2.1.8 条和第 2.1.10 条规定的温度条件的高温环境中，否则可能会导致火灾。在任何正常的充放电使用情况下，电芯温度不能超过 60℃，如果电芯温度超过 60℃，电池管理系统需关闭电池，停止电池运行。

Do not drop cells into fire or expose them to any high temperature environment exceeding operation temperature as set out in paragraphs 2.1.7、2.1.8&2.1.10, otherwise it may cause fire. At all use time, cell temperature should not exceed 60 ° C, shut down system by BMS when it occurs.

5.3 禁止电池正负极短路，否则强电流和高温可能导致人身伤害或者火灾。在电池系统组装和连接时，应有足够的安全保护，以避免短路。

Do not short circuit cell terminals, otherwise high current and temperature may cause body injury or fire hazards. Metallic cell terminals exposed from plastic packaging and ample safety precautions should be

implemented to avoid short circuiting them during system integration or connections.

5.4 严格按照标示和说明连接电池正负极，禁止反向充电。

Always connect cell terminals according to its label(s) in right polarity. Reverse charging is strictly prohibited.

5.5 禁止超过最大功率进行电池充电，和禁止电池过充。否则，可能引起电池过热和火灾事故的发生。

在电池安装和使用中，硬件和软件需实行多重过充失效安全保护。最低保护要求见本技术协议第 4.3 条。

It is extremely dangerous to overcharge a cell which may cause overheating and fire hazards. Multiple level of fail-safe overcharge protection should be implemented by hardware and software. See paragraph 4.3 for minimum requirement to be adopted by the BMS for protection.

5.6 客户应将电池安全地固定在固体平面上，并将电源线安全地束缚在合适的位置，以避免摩擦而引起电弧和火花。

Products should be securely fixed to solid platform, and power cables should be securely attached by fastener to avoid intermittent contact which may cause arcing and sparks.

5.7 严禁用塑料封装电池或用塑料进行电气连接。不正确的电气连接方式可能会造成电池使用过程中发生过热现象。

Do not service cells and electrical connections within plastic package of cell. Improper electrical connection within a cell may cause overheating in service.

5.8 当电解液泄露时，应避免皮肤和眼睛接触电解液。如有接触，应使用大量的清水清洗接触到的区域并向医生寻求帮助。禁止任何人或动物吞食电池的任何部件或电池所含物质。

When the electrolyte leaks, skin and eye contact with the electrolyte should be avoided. In case of contact, a large amount of clean water should be used to clean the contact area and seek help from the doctor. It is forbidden for any person or animal to swallow any part or substance contained in the battery.

5.9 尽力保护电池，使其免受机械震动、碰撞及压力冲击，否则电池内部可能短路，产生高温和火灾。

Protect cells from mechanical shock, impact and pressure. Internal electrical circuit may short circuit to generate high temperature and fire hazards.

5.10 禁止在强静电和强磁场的地方使用，否则易破坏电池安全保护装置，带来安全隐患。

Do not use cells in places with strong static electricity and magnetic field, otherwise the safety protection devices will be damaged, leading to safety risks.

5.11 在进行滥用测试实验时如操作不当可能会引起电池起火或者爆炸。该测试实验只能由配备适当的防护装备的专业人员在专业的实验室进行。否则，可能会导致严重的人身伤害和财产损失。

Battery fire or explosion may be caused by improper operation during abuse test. The test can only be carried out in a professional laboratory by professionals equipped with appropriate protective equipment. Otherwise, it may lead to serious personal injury and property loss.

6. 免责声明 Disclaimer

6.1 如果由于产品需求单位不按本说明书中的规定进行使用，造成社会性影响，并对 AESC 的声誉造成影响，AESC 将会追究产品需求单位的责任。根据对 AESC 造成的影响程度，产品需求单位需向 AESC 提供赔偿。

If the product demand unit does not use the product according to the provisions of this specification, causing social impact and affecting the reputation of AESC, AESC will investigate the responsibility of the product demand unit. According to the degree of impact on AESC, the product demander should provide compensation to AESC.

6.2 AESC 保留对产品的规格及性能参数修改的权利。买方在订购 AESC 产品前，需要与 AESC 提前确认产品的最新状态。

AESC reserves the right to modify the specifications and performance parameters of the product. Before ordering AESC products, the buyer needs to confirm the latest status of the products in advance with AESC.

6.3 英文规格释义仅供参考，请以中文版技术规格要求为准。

English specifications are for reference only. Please refer to the technical specifications of the Chinese version.