

1. Product Description

This rack mode lifepo4 lithium battery belongs to one of the series of household energy storage products that are independently designed and developed. It has long cycle life, high safety standard BMS software protection and strong housing, exquisite looks, and easy installation, etc. It is widely used in energy storage system with off-grid inverters, on-off grid inverters and hybrid inverters.

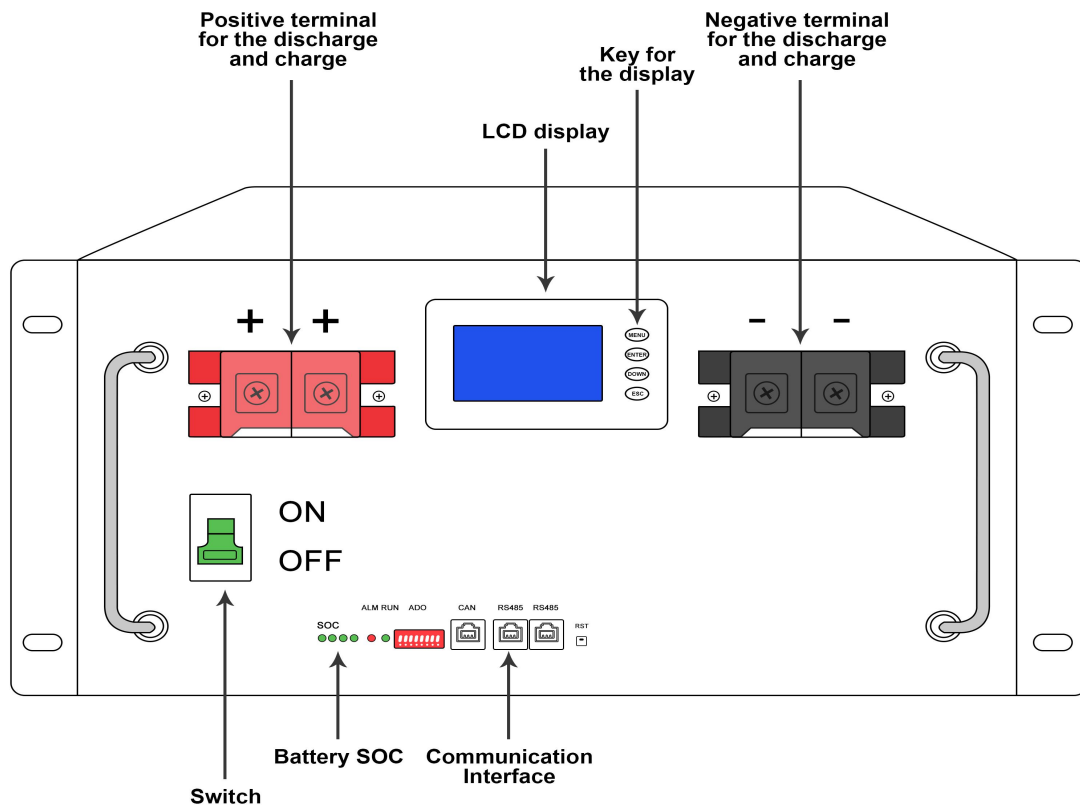

*This interface design is only for reference, it may change according to different demands